

Leghe a memoria di forma (SMA)

La trasformazione martensitica

Effetto superelastico

Effetto memoria di forma

Applicazioni SMA

Damping e applicazioni come smorzatore di vibrazioni

La trasformazione martensitica

- Trasformazione displasiva, che coinvolge solo delle rotazioni e traslazioni atomiche e nessuna rottura di legame

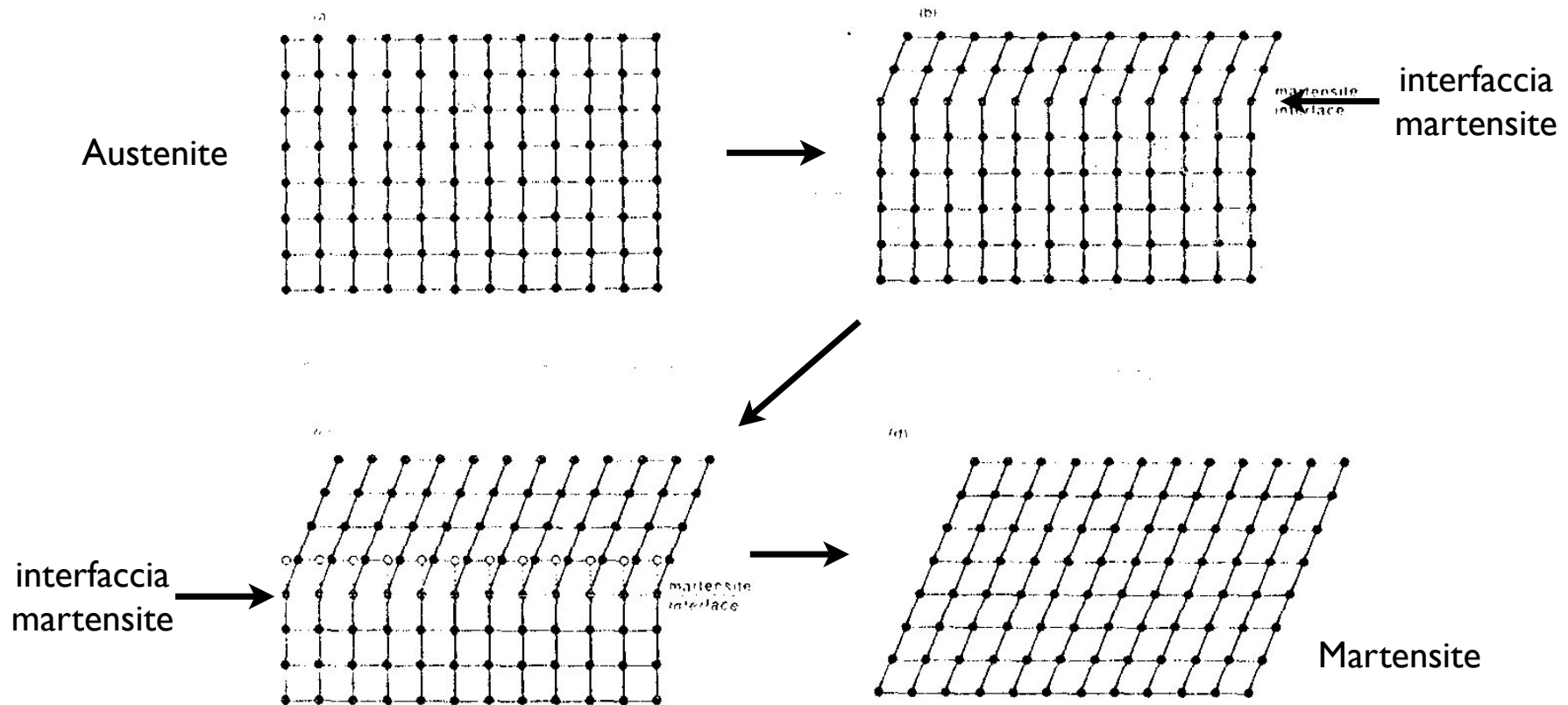

- La trasformazione da austenite a martensite è ostacolata dalla matrice intorno che costringe il grano a mantenere la propria forma. Allora possiamo avere slip di accomodamento o twinning:

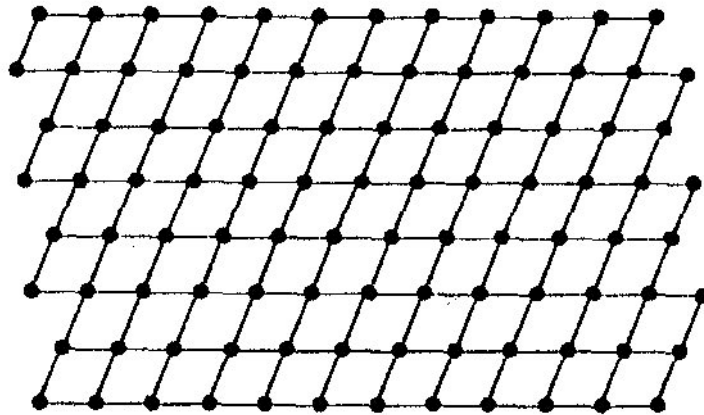

(a) Accommodation by slip

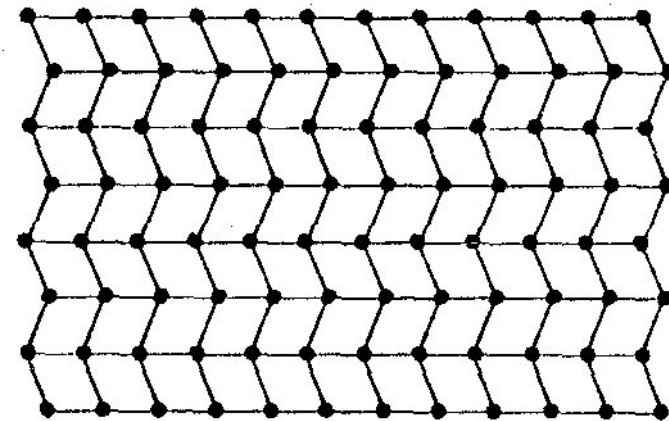

(b) Accommodation by twinning

Costrizione della matrice

Trasformazione martensitica e proprietà

- Monitorando le proprietà si nota un'isteresi nella trasformazione

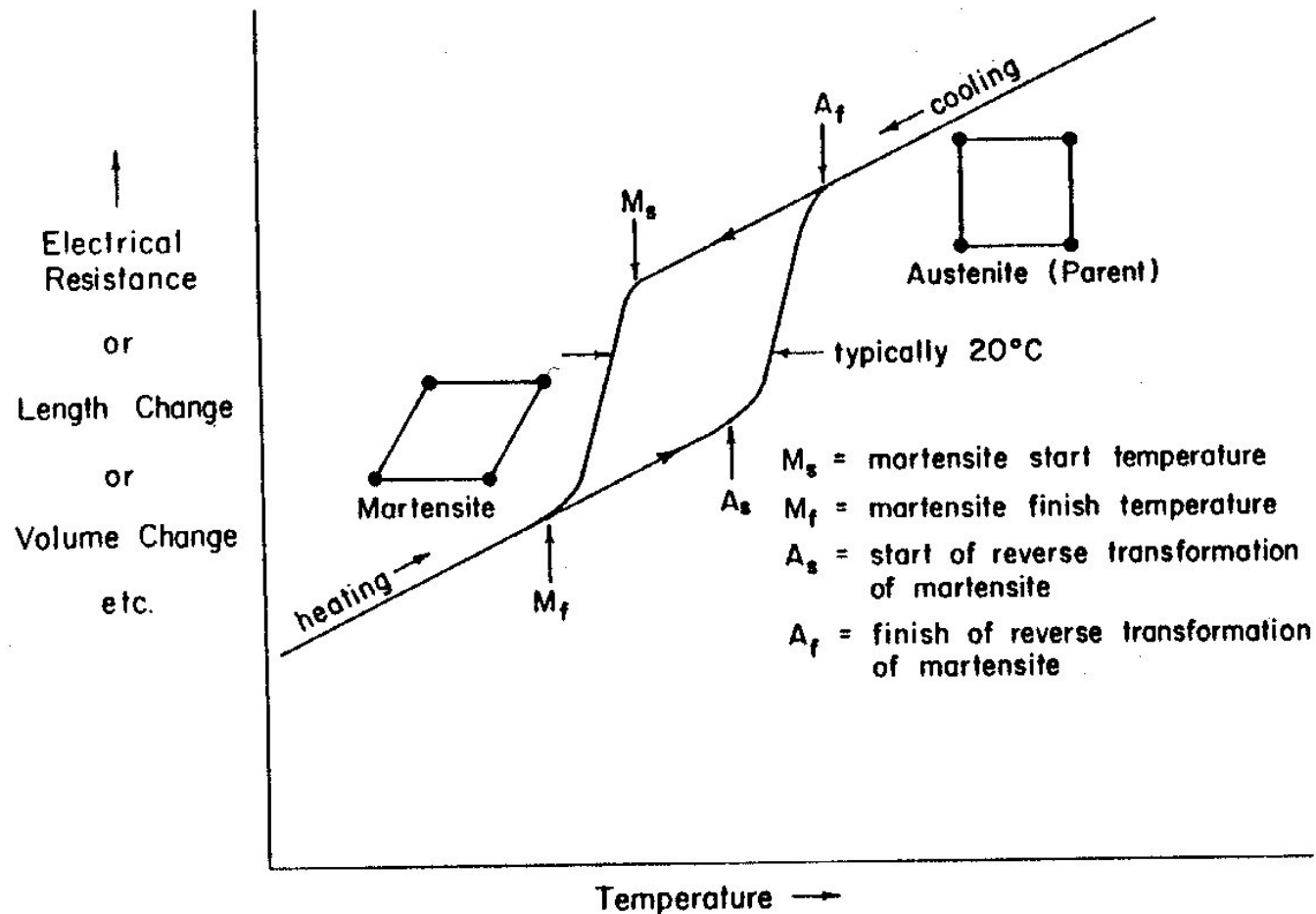

Caratteristiche del twinning

- La geminazione è una deformazione del cristallo possibile con alcune simmetrie cristalline. Il bordo di geminato divide due zone simmetriche rispetto al piano del geminato. Si ottengono per sforzo di taglio.

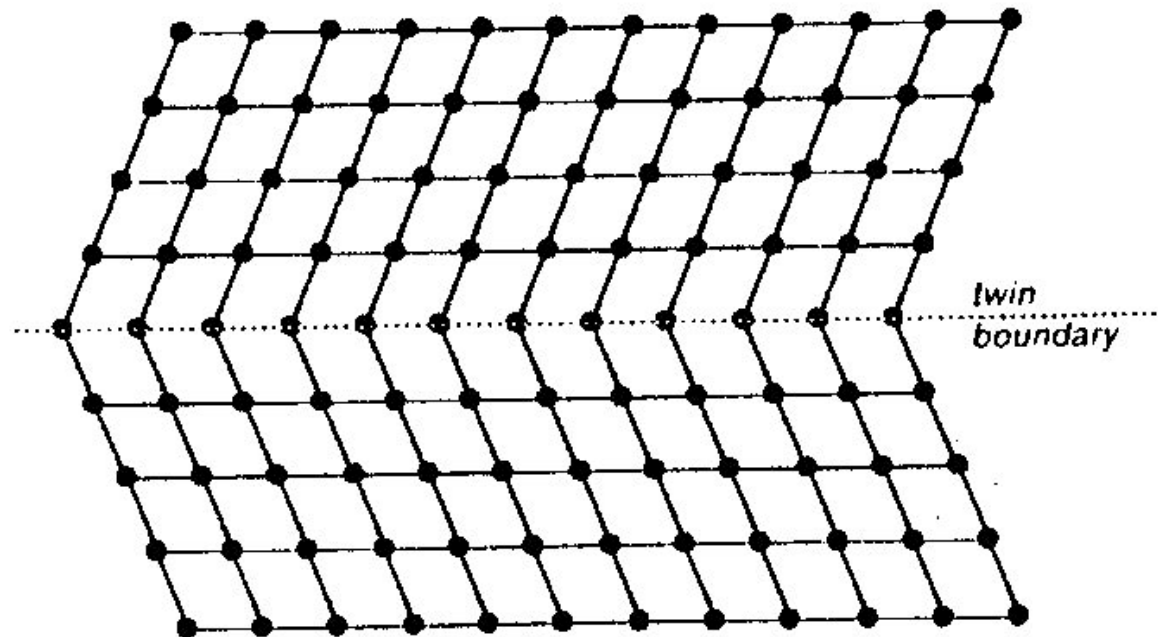

Detwinning

- Il meccanismo di detwinning permette una deformazione notevole senza slittamento dei piani (è comunque una deformazione plastica)

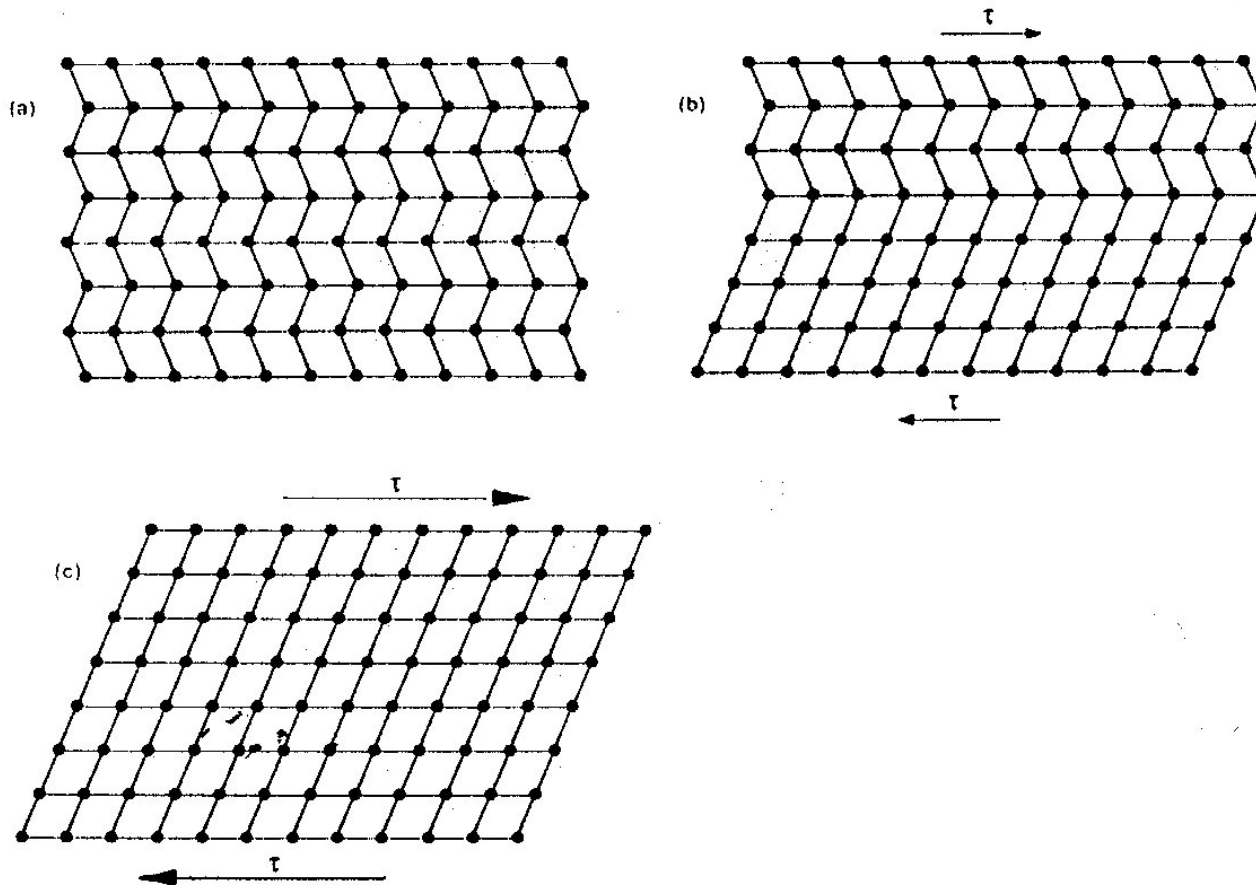

La curva sforzo-deformazione per la martensite

- La martensite proveniente da trasformazione austenite-martensite prima si deforma elasticamente, poi per detwinning, infine abbiamo deformazione plastica usuale per slip

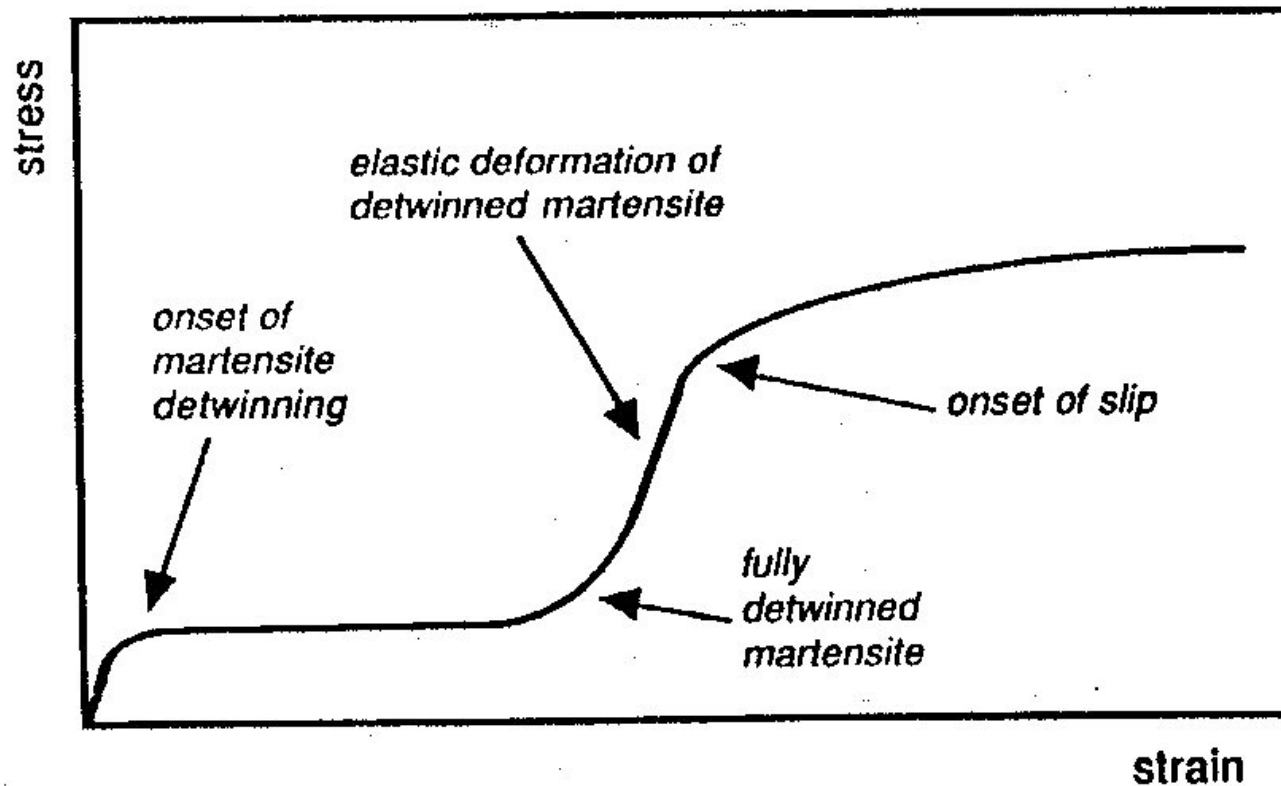

Detwinning e curva sforzo-deformazione

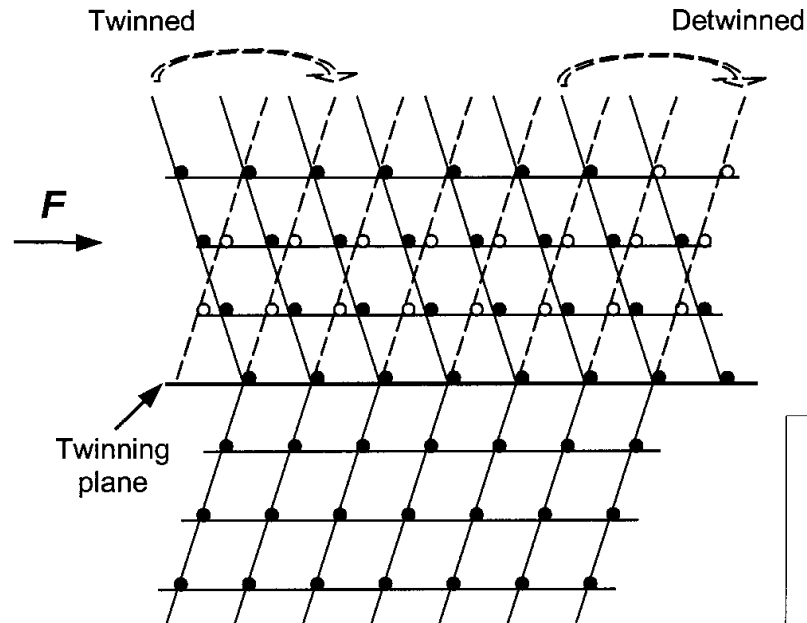

Martensite

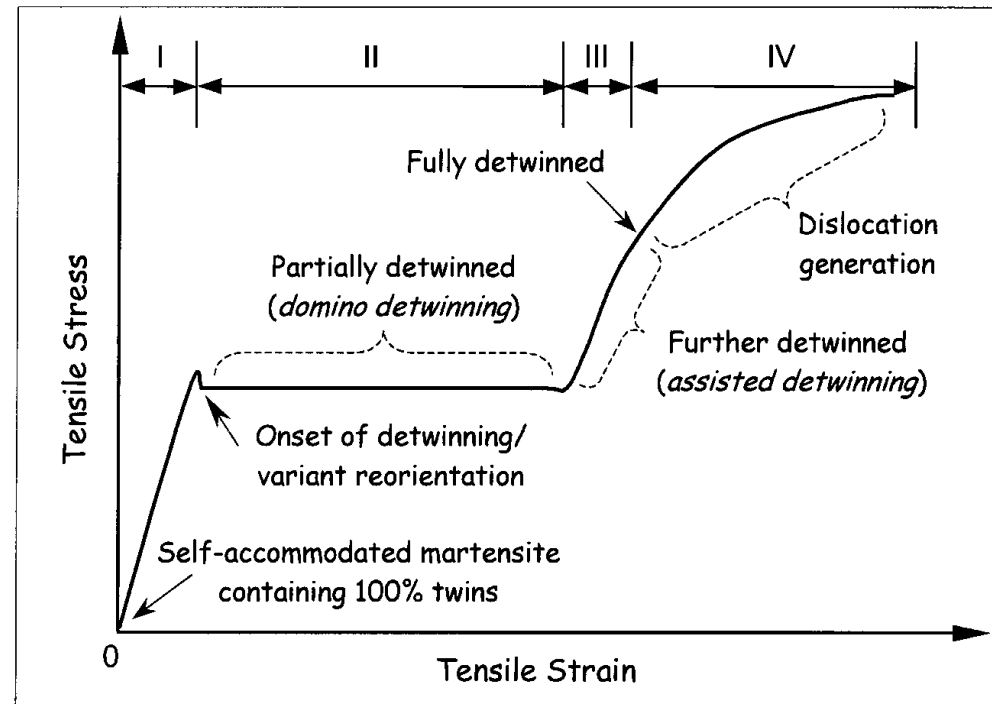

Sforzo-deformazione per l'austenite

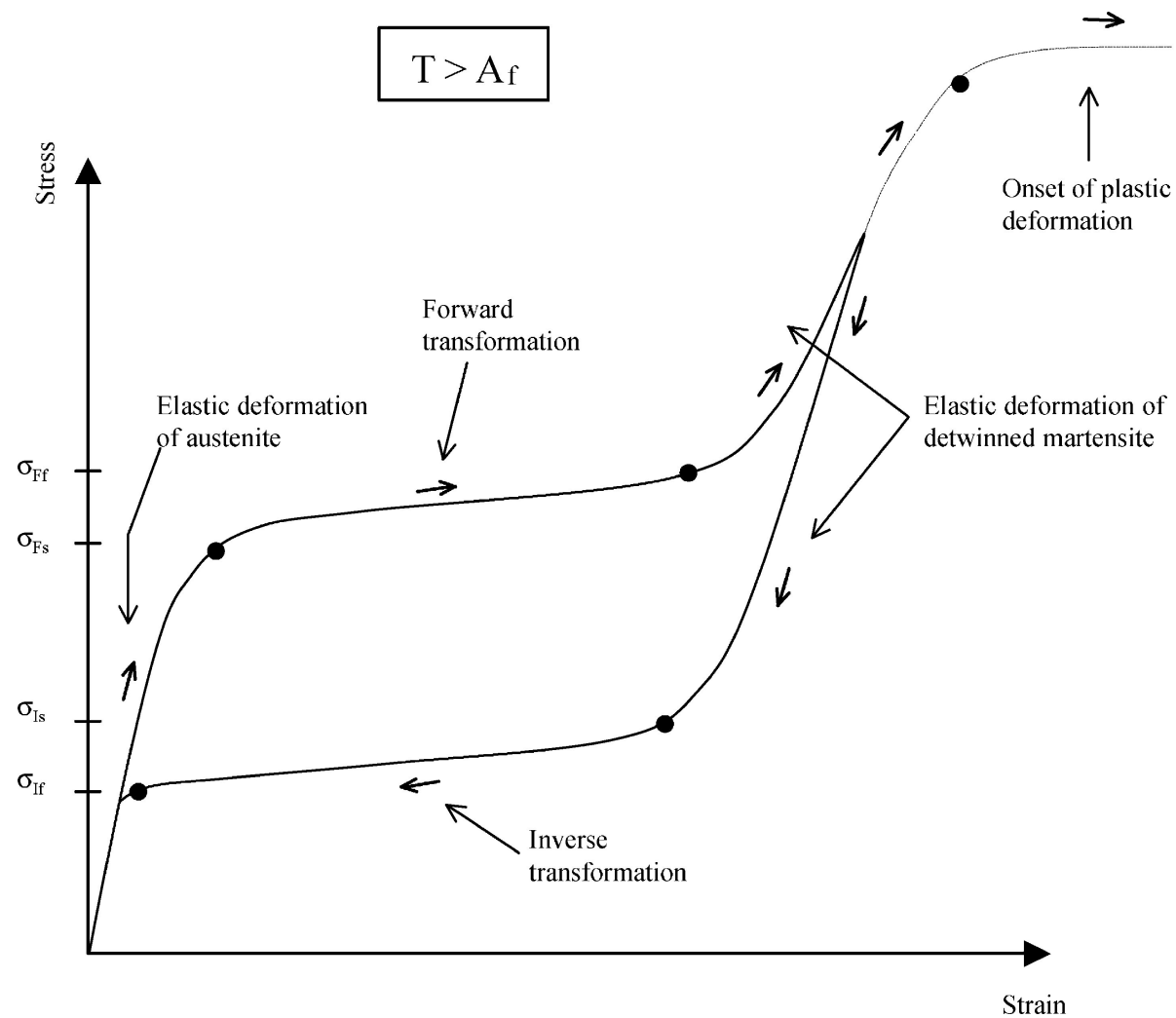

Cosa cambia nella curva con la temperatura?

- Con l'aumento della temperatura il plateau di trasformazione o detwinning (se da austenite o martensite) avviene a temperatura più elevata

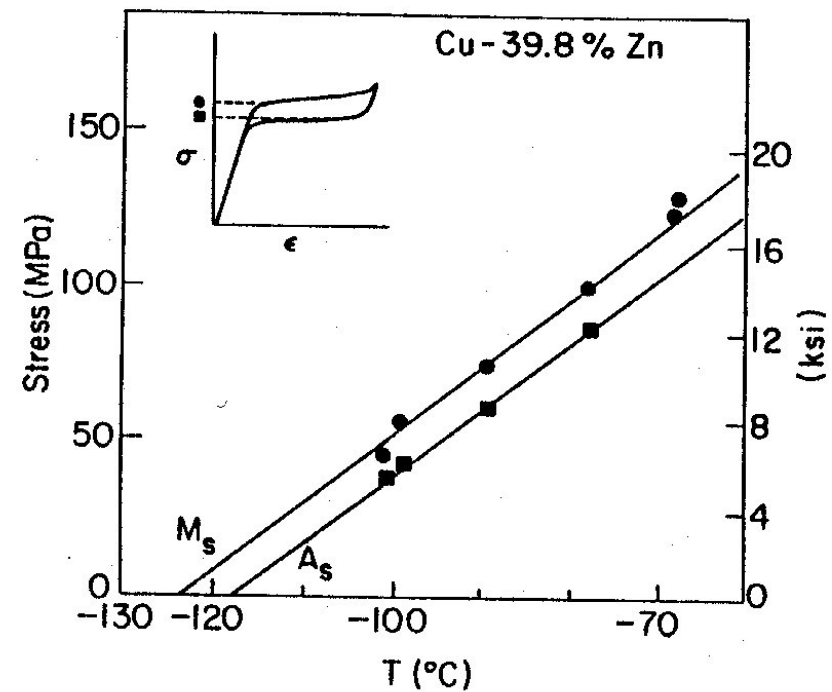
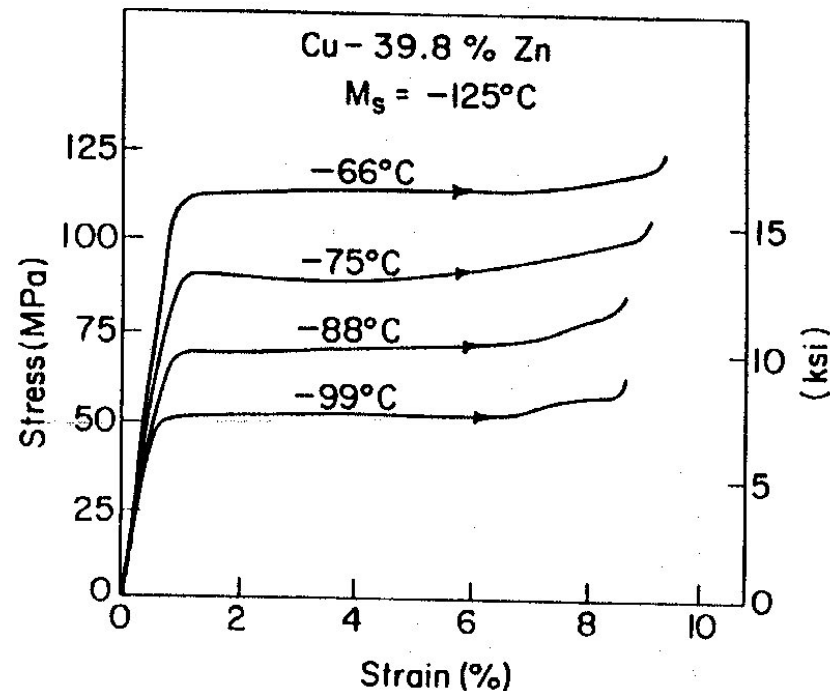

La memoria di forma

- Partiamo da austenite, raffreddiamo, deformiamo la martensite (per detwinning), riscaldiamo e ritrasformiamo in austenite. La rotazione delle celle forza i grani a tornare alla forma originale con recupero della forma iniziale del pezzo.

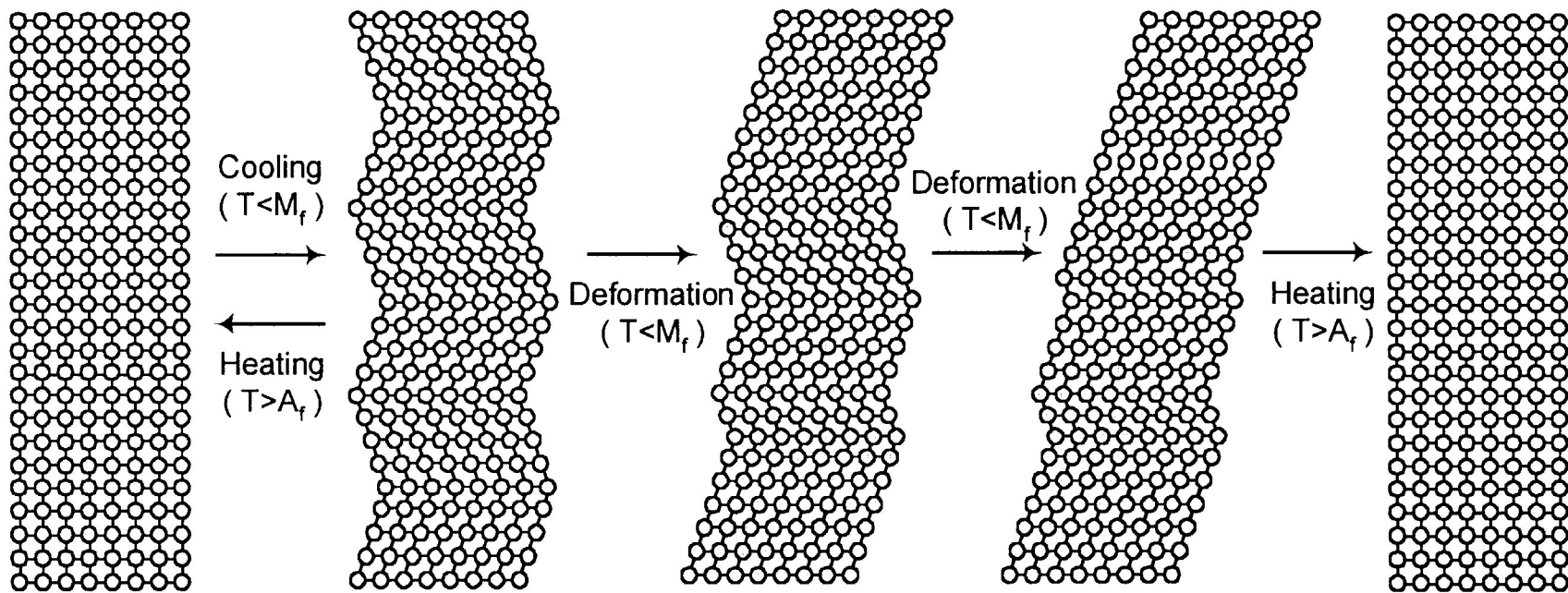

Memoria di forma in sintesi

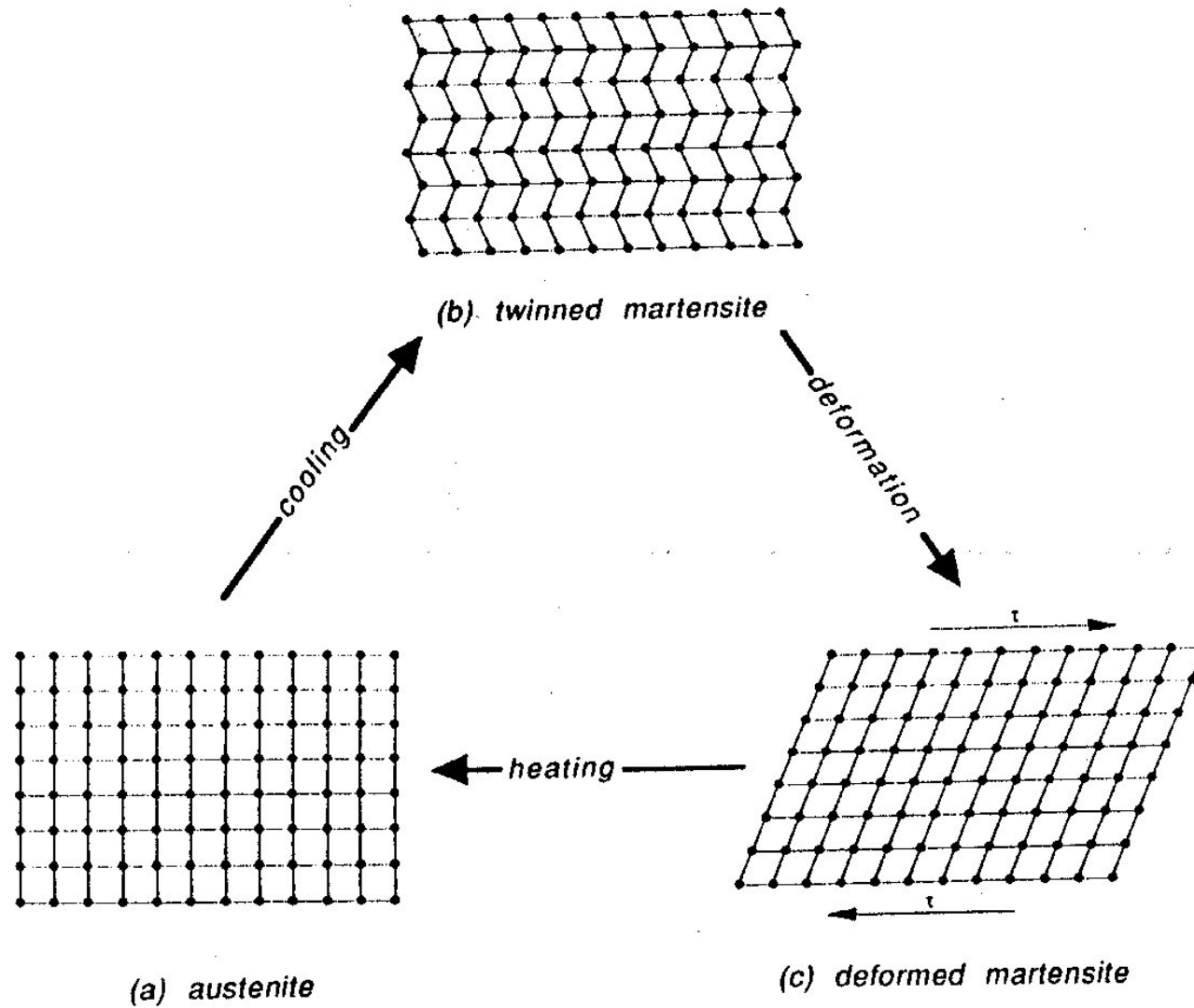

SMA: memoria di forma e superelasticità

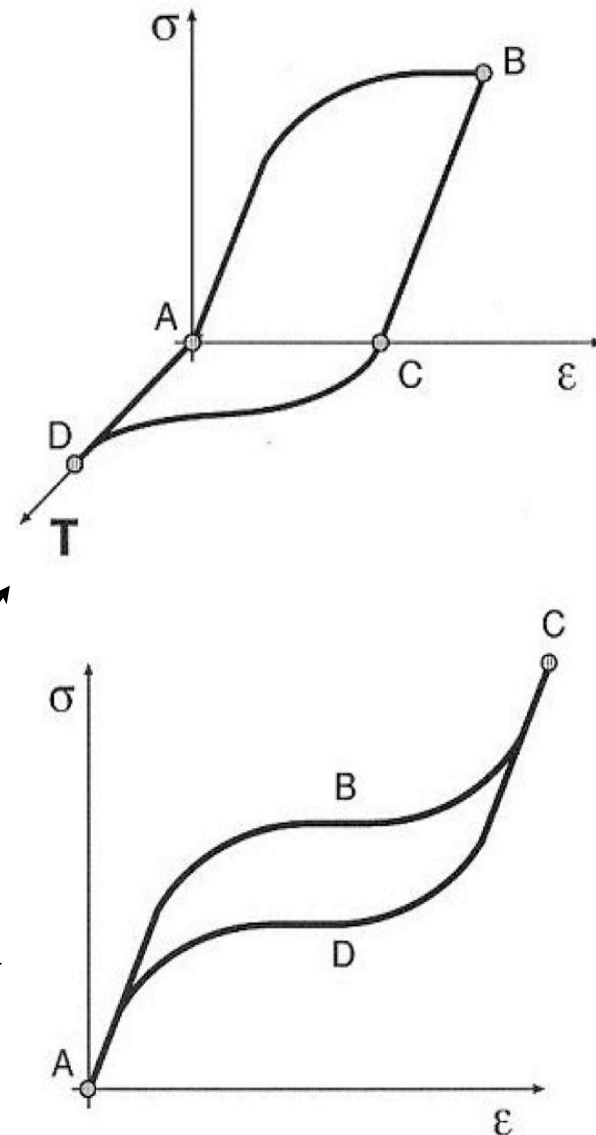
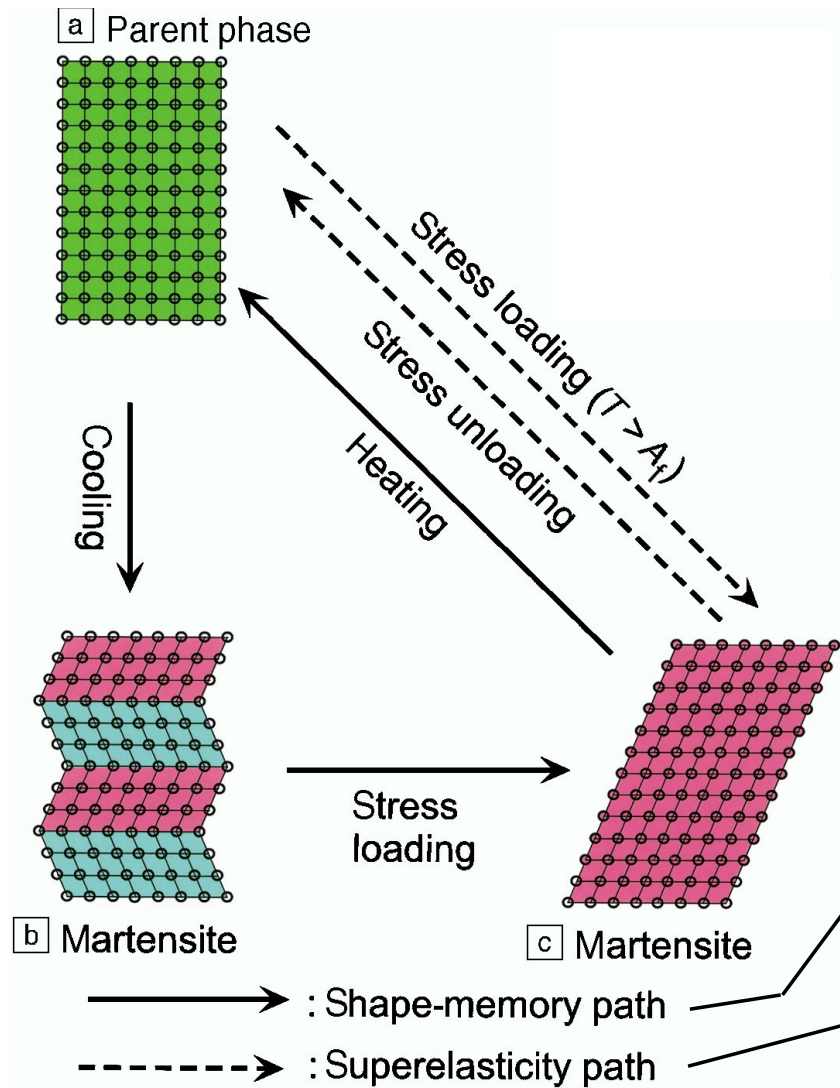

Curva sforzo-deformazione-temperatura

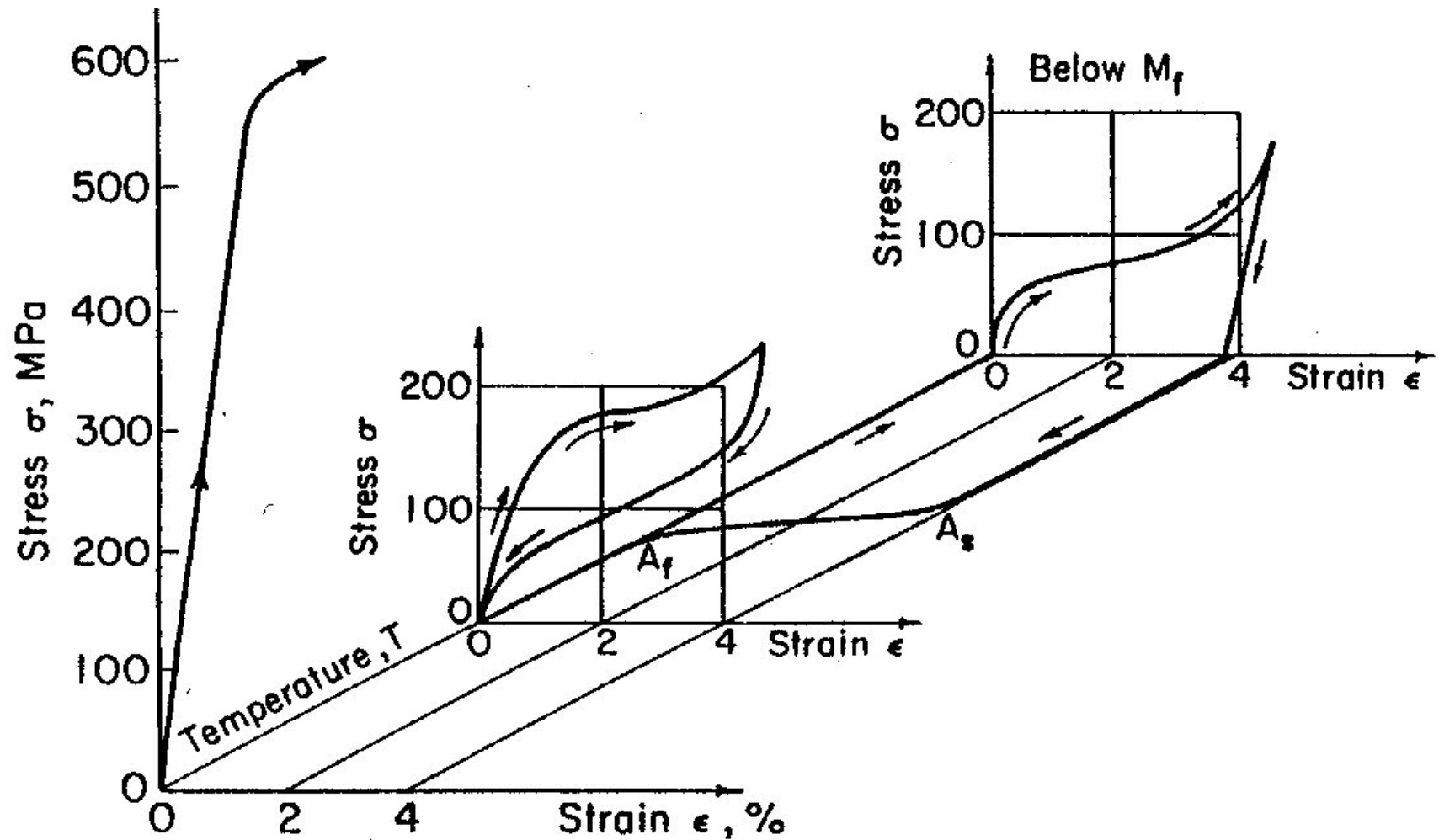

Memoria a due vie

- Memoria di forma a una via: si deforma in fase martensitica e riscaldando sopra la A_f il pezzo recupera la propria forma iniziale
- Memoria a due vie: il pezzo viene sottoposto a training in modo che a bassa e alta temperatura assuma due forme diverse stabilmente

One-way memory

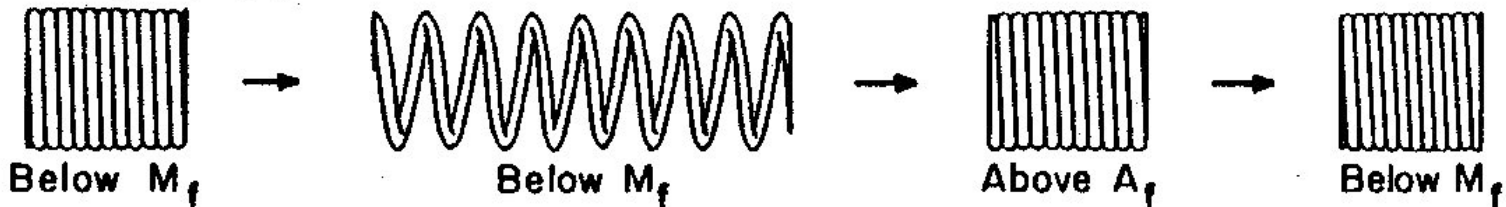

Two-way memory

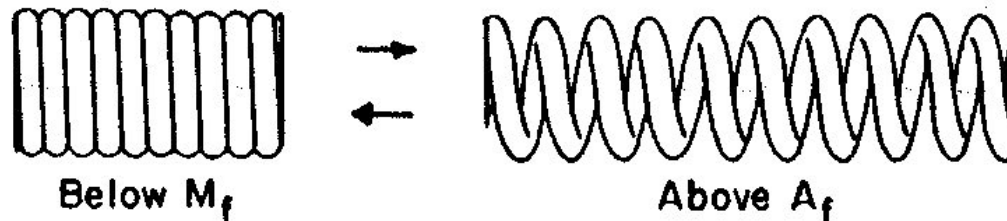

Training

- Il pezzo viene sottoposto a cicli termici nei quali ad alta temperatura (austenite) lo si forza in una forma e a bassa temperatura (martensite) in un'altra forma
- Il ciclaggio viene portato avanti finchè il pezzo assume stabilmente le due forme.
- La memoria a due vie viene utilizzata per attuatori che facciano un determinato lavoro a seguito di aumento e decremento di temperatura sopra e sotto le temperature di trasformazione finali.

Temperatura-sforzo vs. stabilità delle fasi

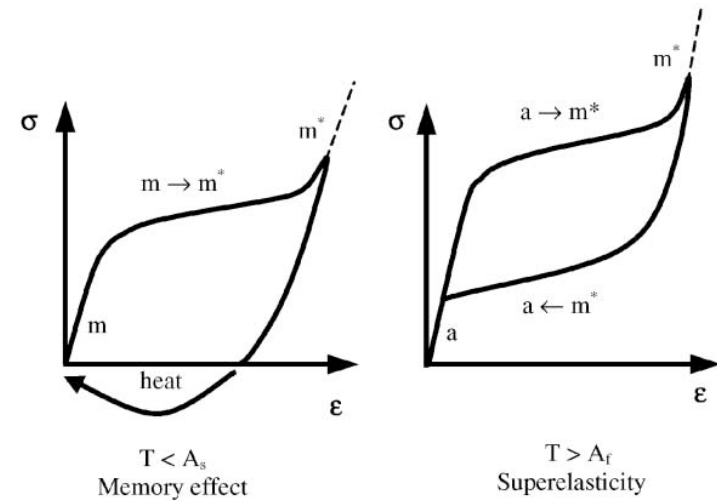
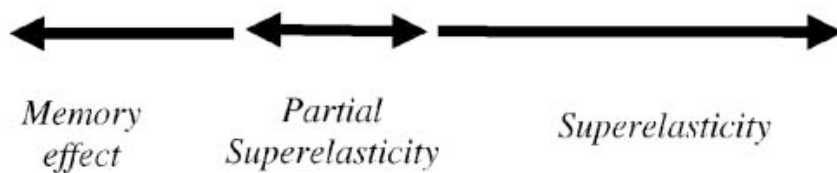
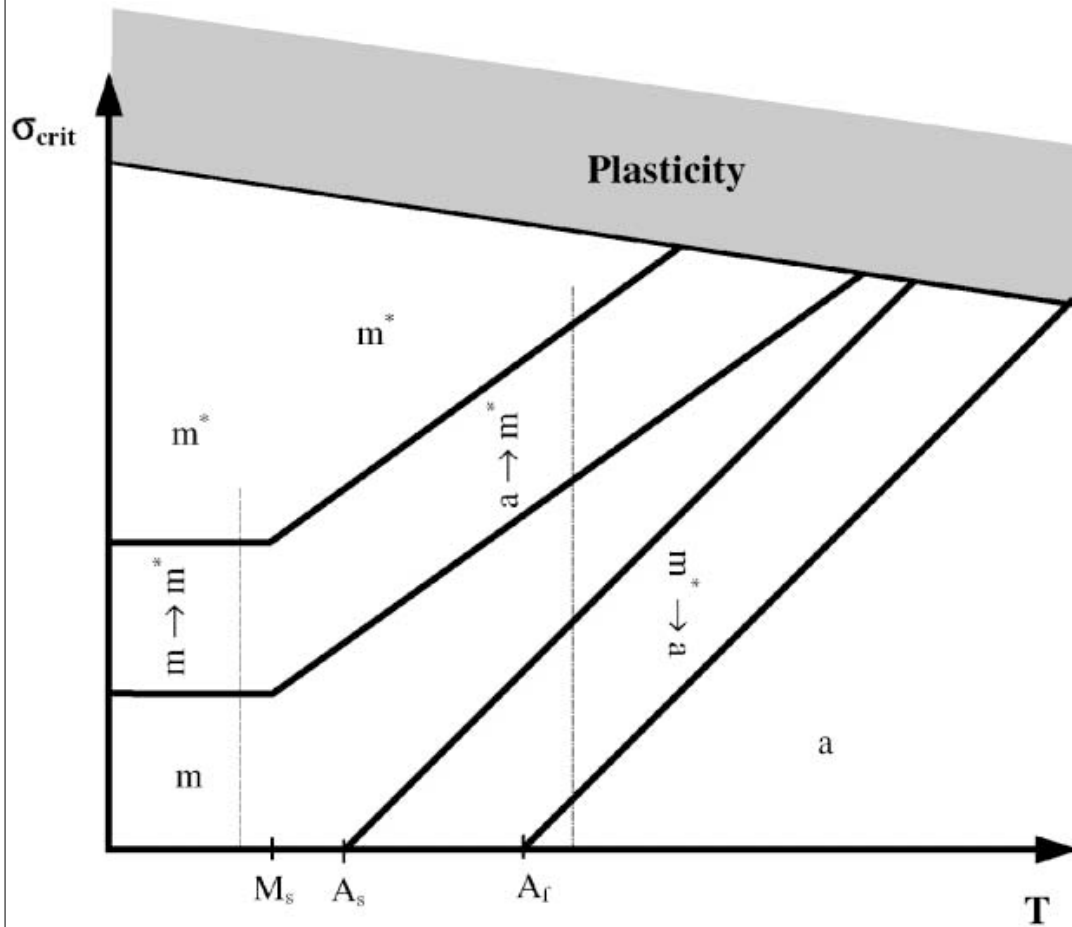

NOTATIONS :

- a : austenite
- m : twinned martensite
- m^* : detwinned martensite

Tipi di leghe a memoria di forma

Alloy type	Composition	Temp. range [$^{\circ}C$]	Hyst. [$^{\circ}C$]
Ag-Cd	44/49 at. % Cd	-190 to -50	15
Au-Cd	46.5/50 at. % Cd	30 to 100	15
Cu-Al-Ni	14/14.5 at. % Al 3/4.5 wt. % Ni	-140 to 100	35
Cu-Sn	\approx 15 at. % Sn	-120 to 30	
Cu-Zn	38.5/41.5 wt. % Zn	-180 to -10	10
In-Ti	18/23 at. % Ti	60 to 100	4
Ni-Al	36/38 at. % Al	-180 to 100	10
Ni-Ti	49/51 at. % Ni	-50 to 110	30
Fe-Pt	\approx 25 at. % Pt	-130	4
Mn-Cu	5/35 at. % Cu	-250 to 180	24
Fe-Mn-Si	32 wt. % Mn, 6 wt. % Si	-200 to 150	100

Prprietà delle leghe Ni-Ti

Melting temperature	1300	[°C]
Density	6.45	[g/cm ³]
Resistivity austenite	≈ 100	[μΩ cm]
Resistivity martensite	≈ 70	[μΩ cm]
Thermal conductivity austenite	18	[W/(cm°C)]
Thermal conductivity martensite	8.5	[W/(cm°C)]
Corrosion resistance	similar to Ti alloys	
Elasticity Modulus austenite	≈ 80	[MPa]
Elasticity Modulus martensite	≈ 20 to 40	[MPa]
Yield strength austenite	190 to 700	[MPa]
Yield strength martensite	70 to 140	[MPa]
Ultimate tensile strength	≈ 900	[MPa]
Transformation tmperature	-200 to 110	[°]
Shape memory strain	8.5	[%]

Altre leghe SMA

Alloy type	CuZnAl	CuAlNi	
Melting temperature	950 to 1020	1000 to 1050	[°C]
Density	7.64	7.12	[g/cm ³]
Resistivity	8.5 to 9.7	11 to 13	[μΩ cm]
Thermal conductivity	120	30 to 43	[W/(cm°C)]
Elasticity Modulus austenite	72 (*)	85 (*)	[MPa]
Elasticity Modulus martensite	70 (*)	80 (*)	[MPa]
Yield strength austenite	350	400	[MPa]
Yield strength martensite	80	130	[MPa]
Ultimate tensile strength	600	500 to 800	[MPa]
Transformation temperature	≤ 120	≤ 200	[°C]
Shape memory strain	4	4	[%]

Confronto NiTi-acciai

Property	NiTi SMA	Steel
Recoverable elongation [%]	8	2
Modulus of elasticity [MPa]	8.7×10^4 (A), 1.4×10^4 (M)	2.07×10^5
Yield strength [MPa]	200-700 (A), 70-140 (M)	248-517
Ultimate tensile strength [MPa]	900 (f.a.), 2000 (w.h.)	448-827
Elongation at failure [%]	25-50 (f.a.), 5-10 (w.h.)	20
Corrosion performace	Excellent	Fair

Diagramma di fase binario Ni-Ti

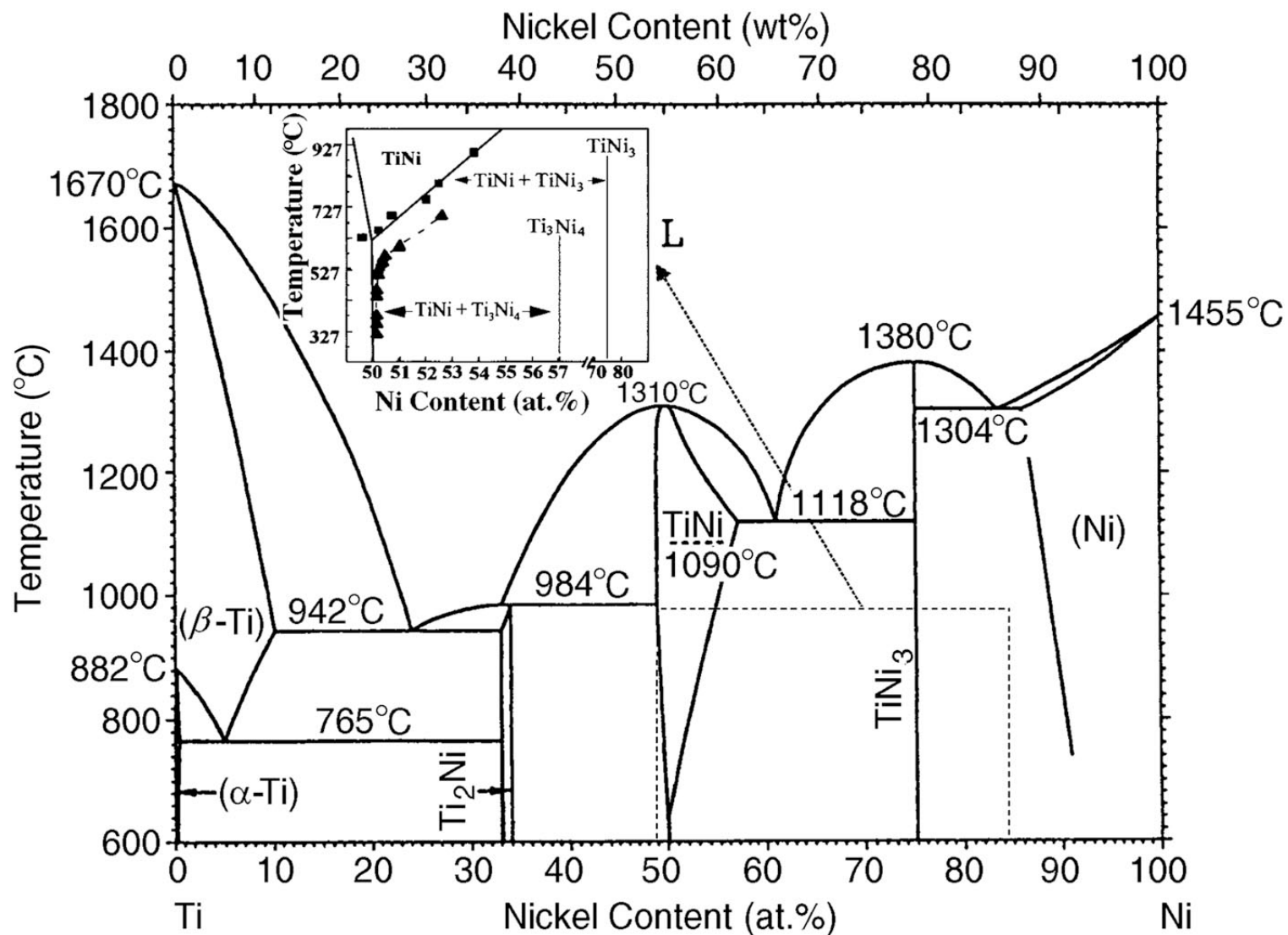

Applicazioni SMA: memoria ad una via

- L'attuatore più semplice: a bassa temperatura il peso deforma per gravità la molla nello stato martensitico (la martensite ha un modulo elastico più basso dell'austenite). Ad alta temperatura si ritrasforma e la molla recupera lo stato iniziale

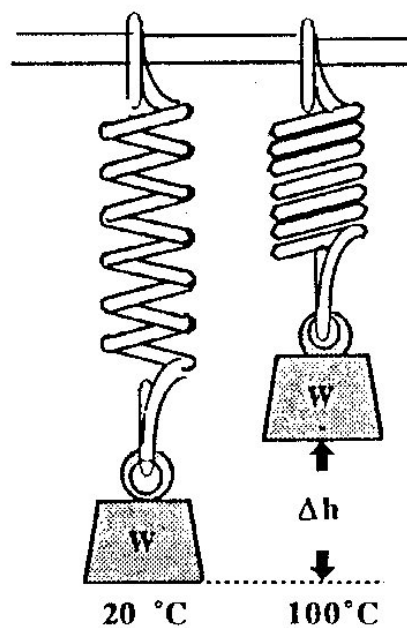

Applicazioni SMA: giunzioni

Sistemi di giunzione e
rilascio nello spazio

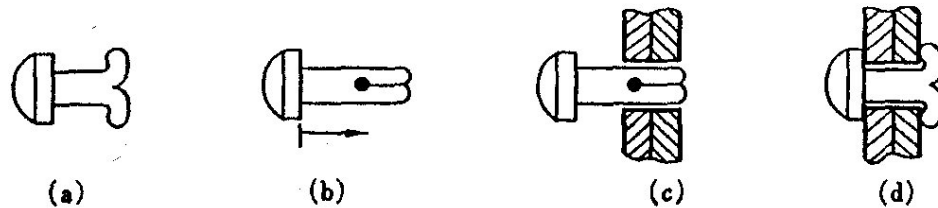
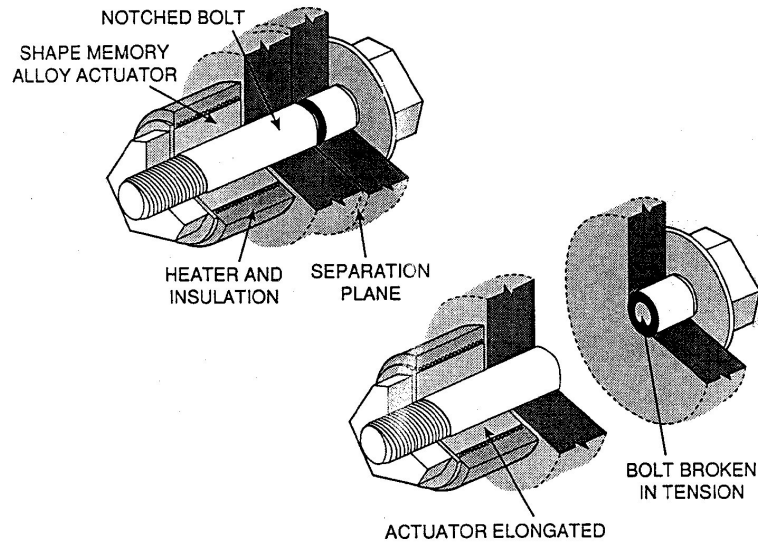

Rivetti autobloccanti:

insert after cooling fasten at room temperatures.

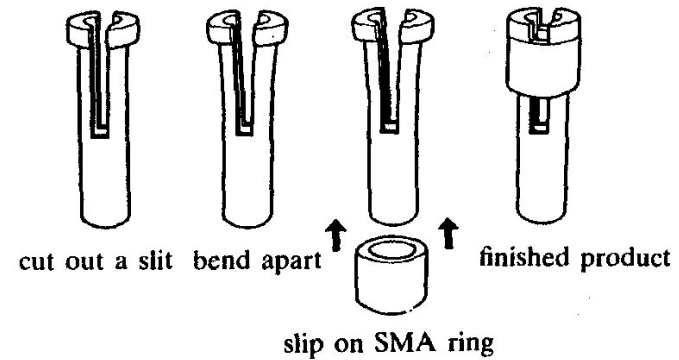
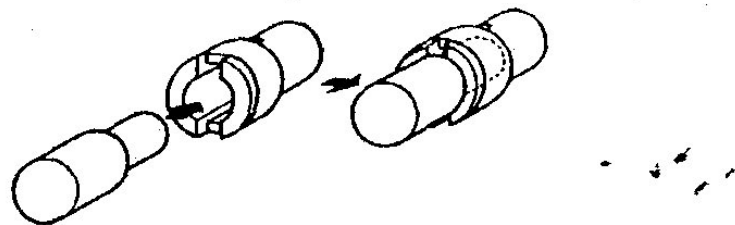

Flange di giunzione

- Si allargano in pressione
- Si applicano
- Si riscalda e si restringono applicando un carico progettabile accuratamente

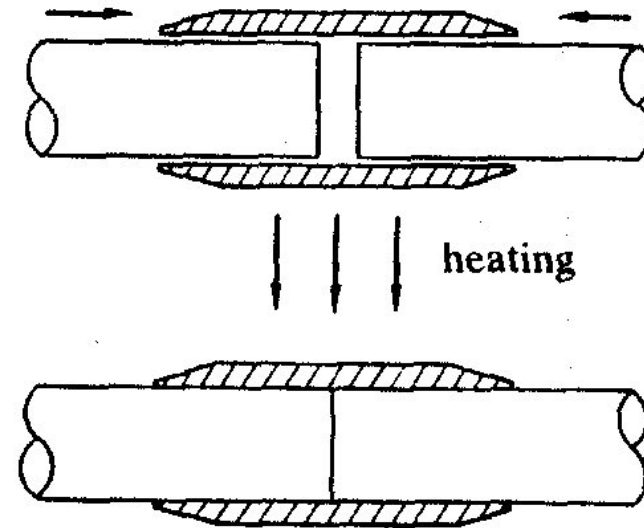

Giunzioni e anelli di tenuta

- Clamps:

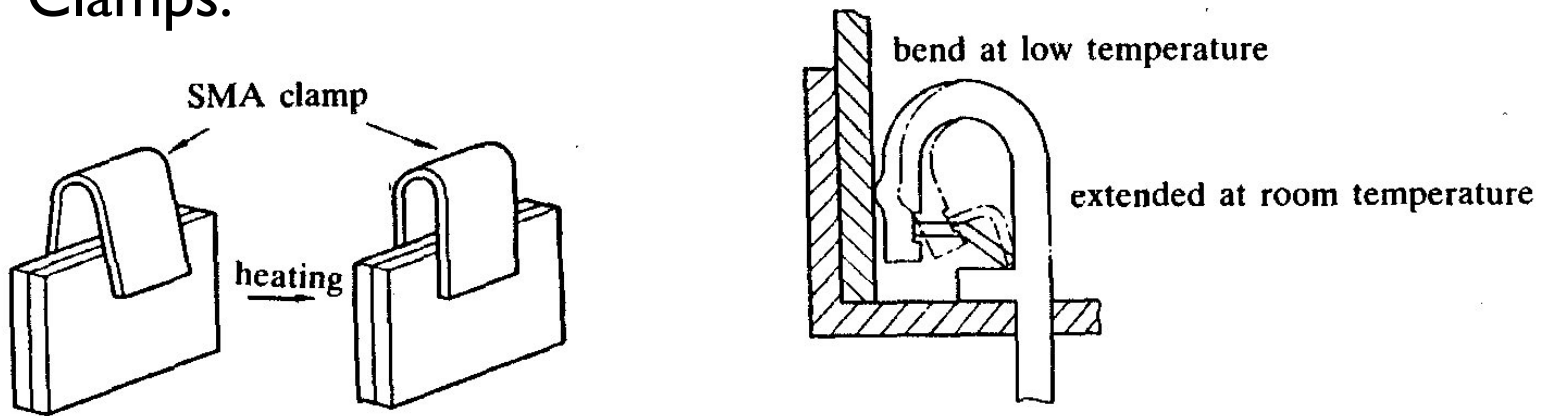

- Anelli di tenuta

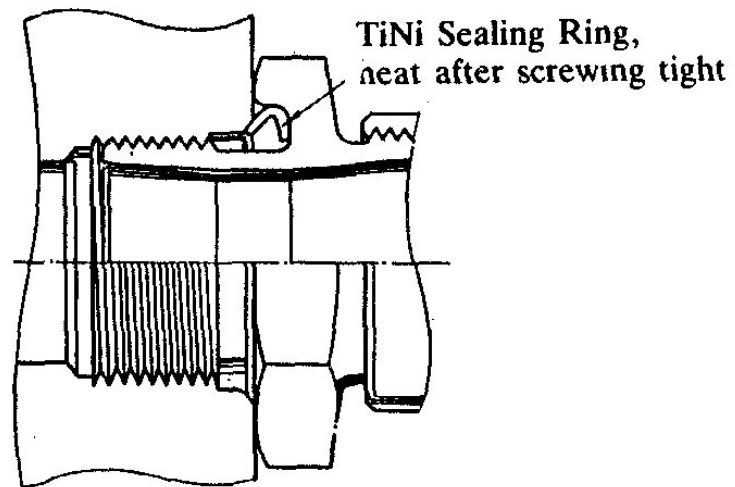

Applicazioni SMA: valvola termostatica

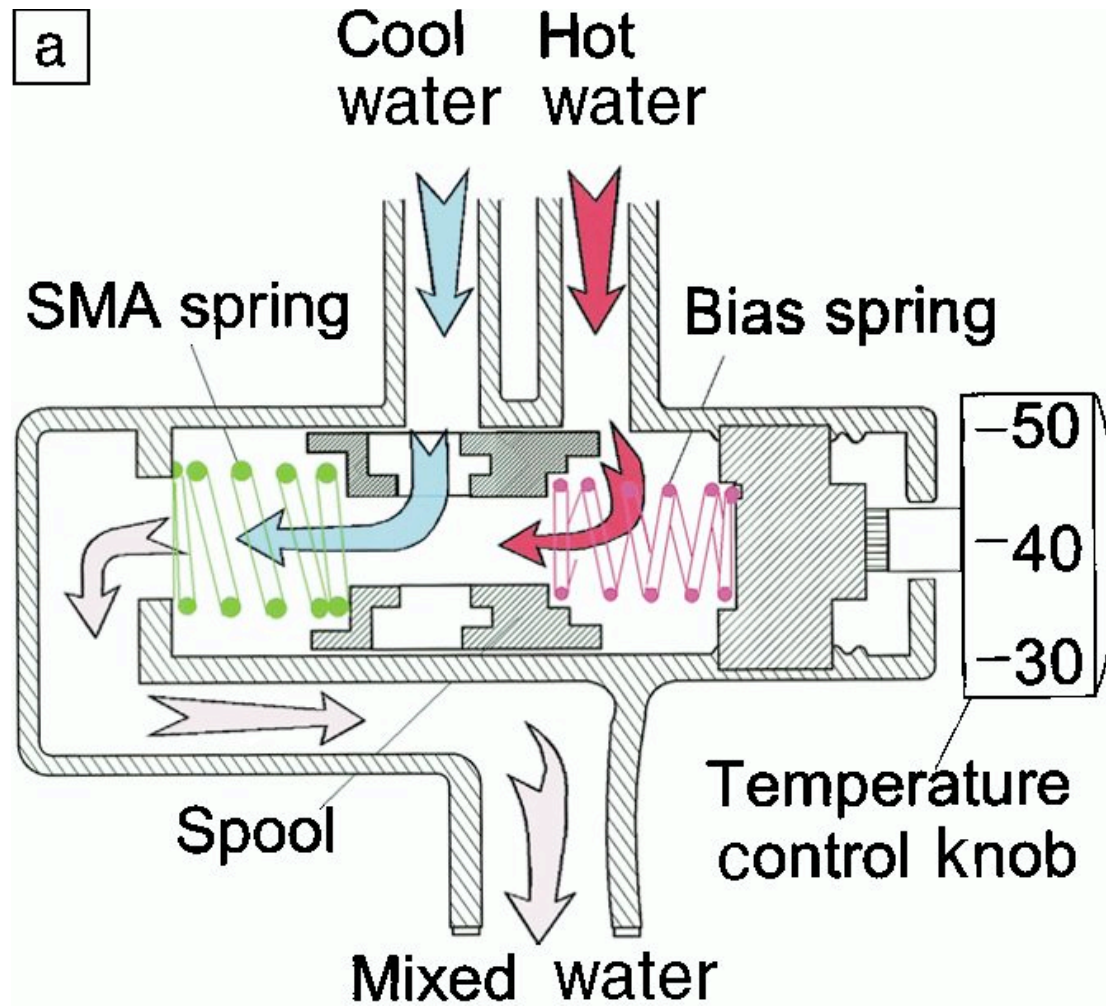

Dimensionamento dispositivo a doppia molla

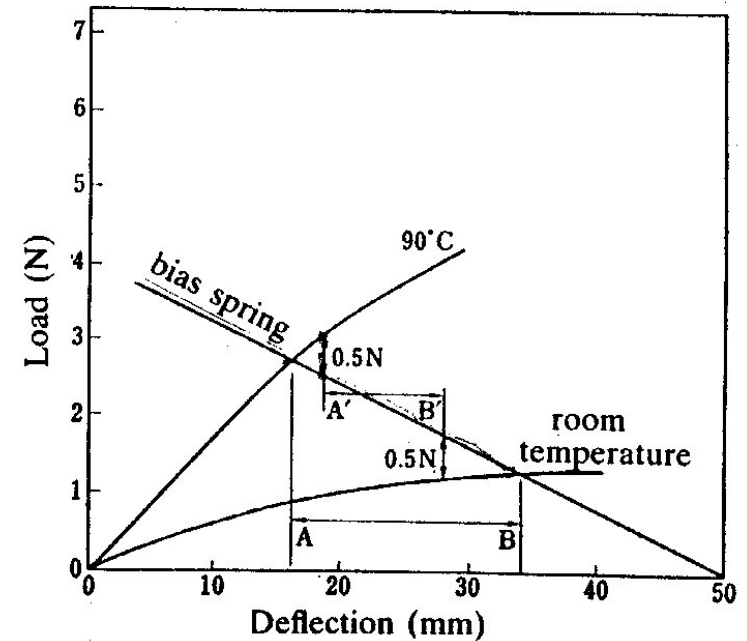
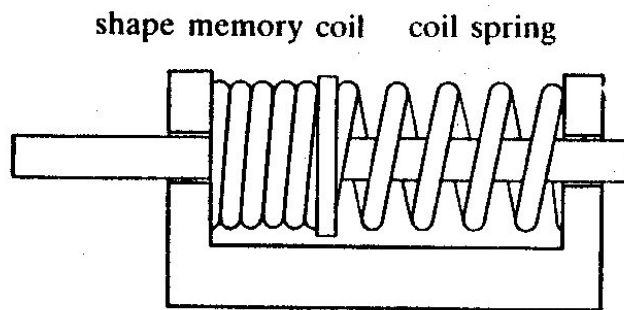
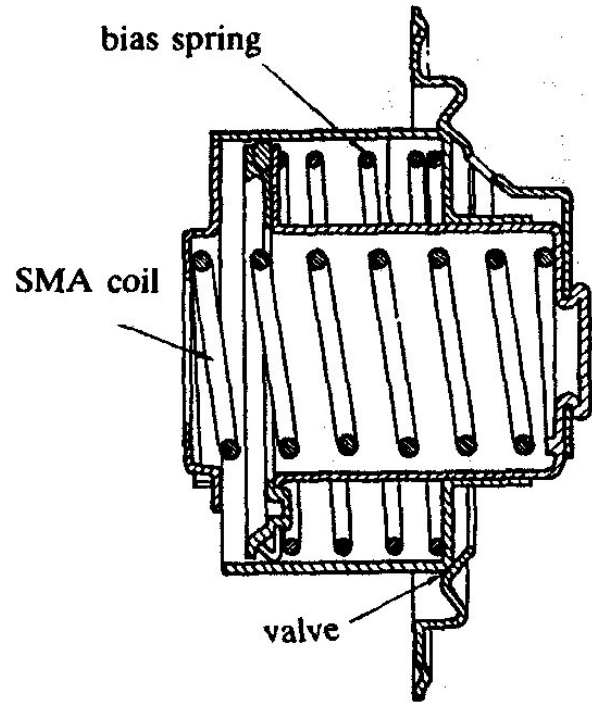

Uso delle valvole sui treni ad alta velocità

a

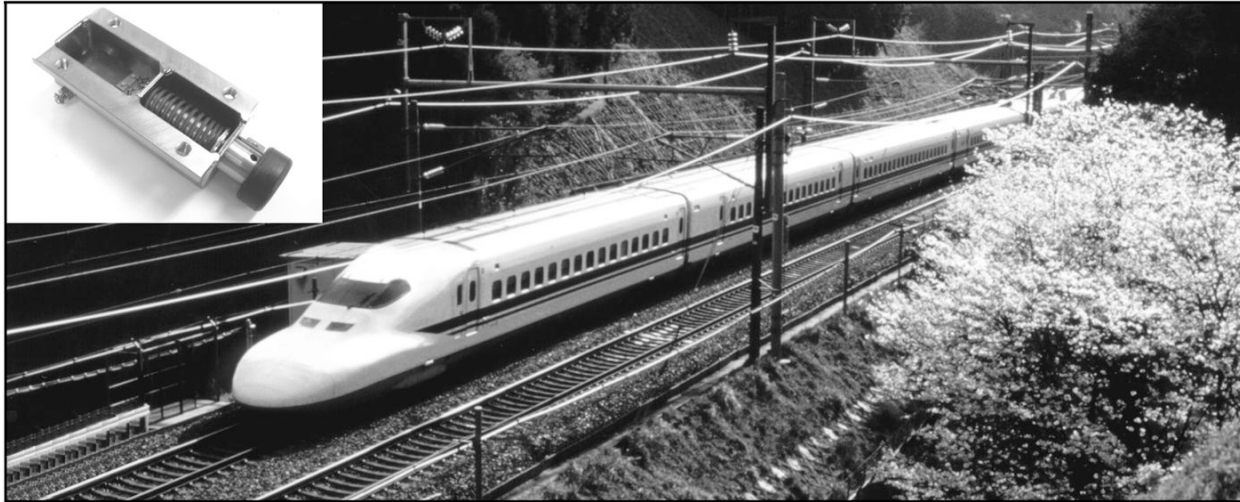

b

(Low temperature)

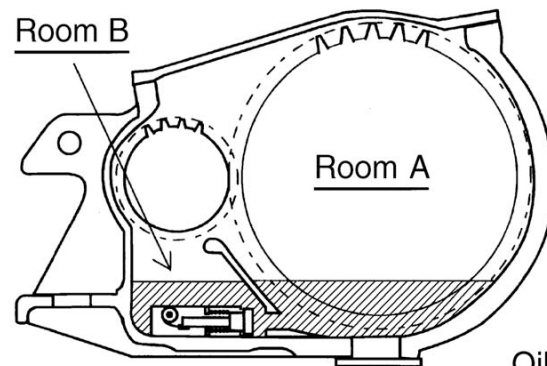

c

(High temperature)

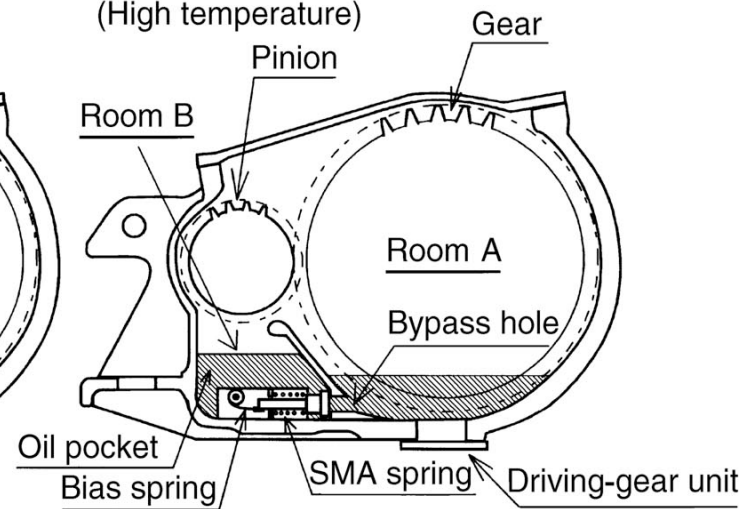

Memoria a due vie: sonda chirurgica

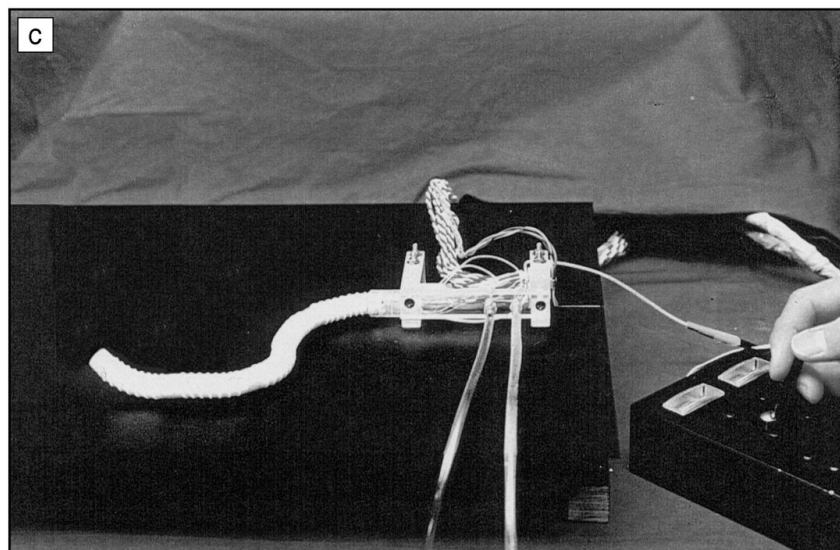
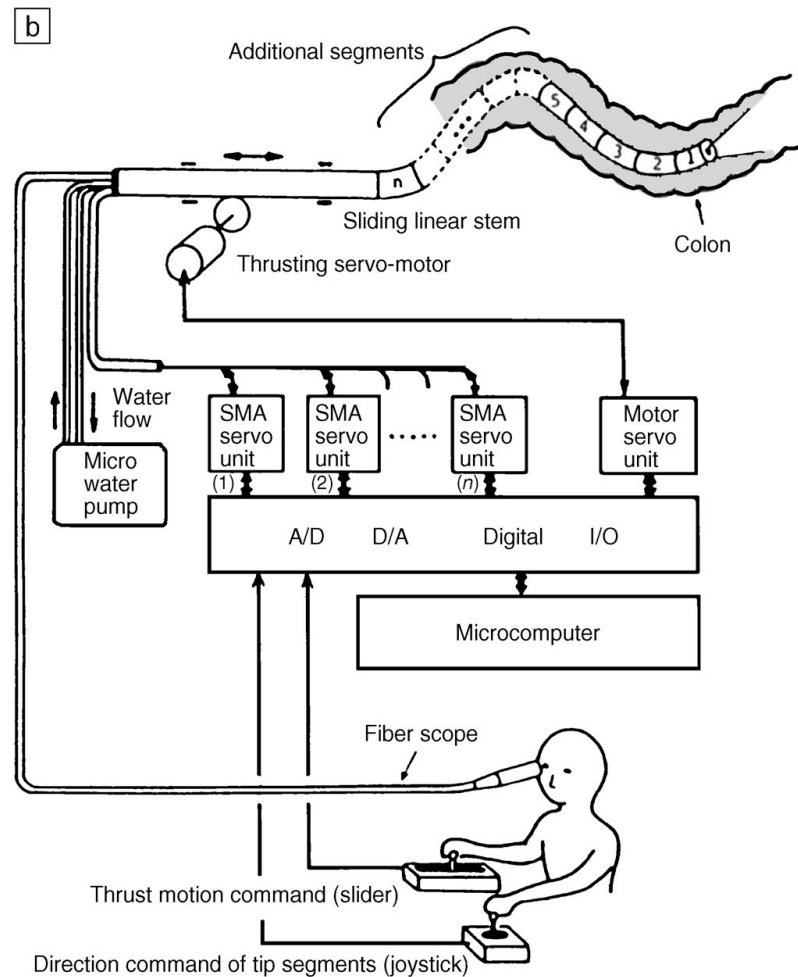
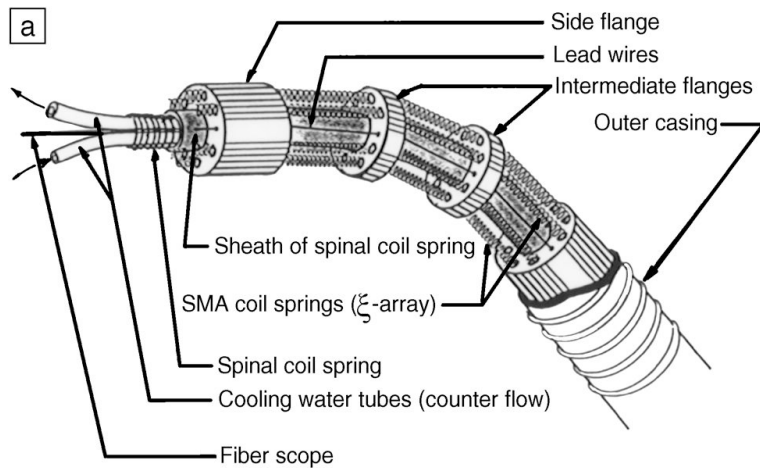

Comportamento superelastico e damping

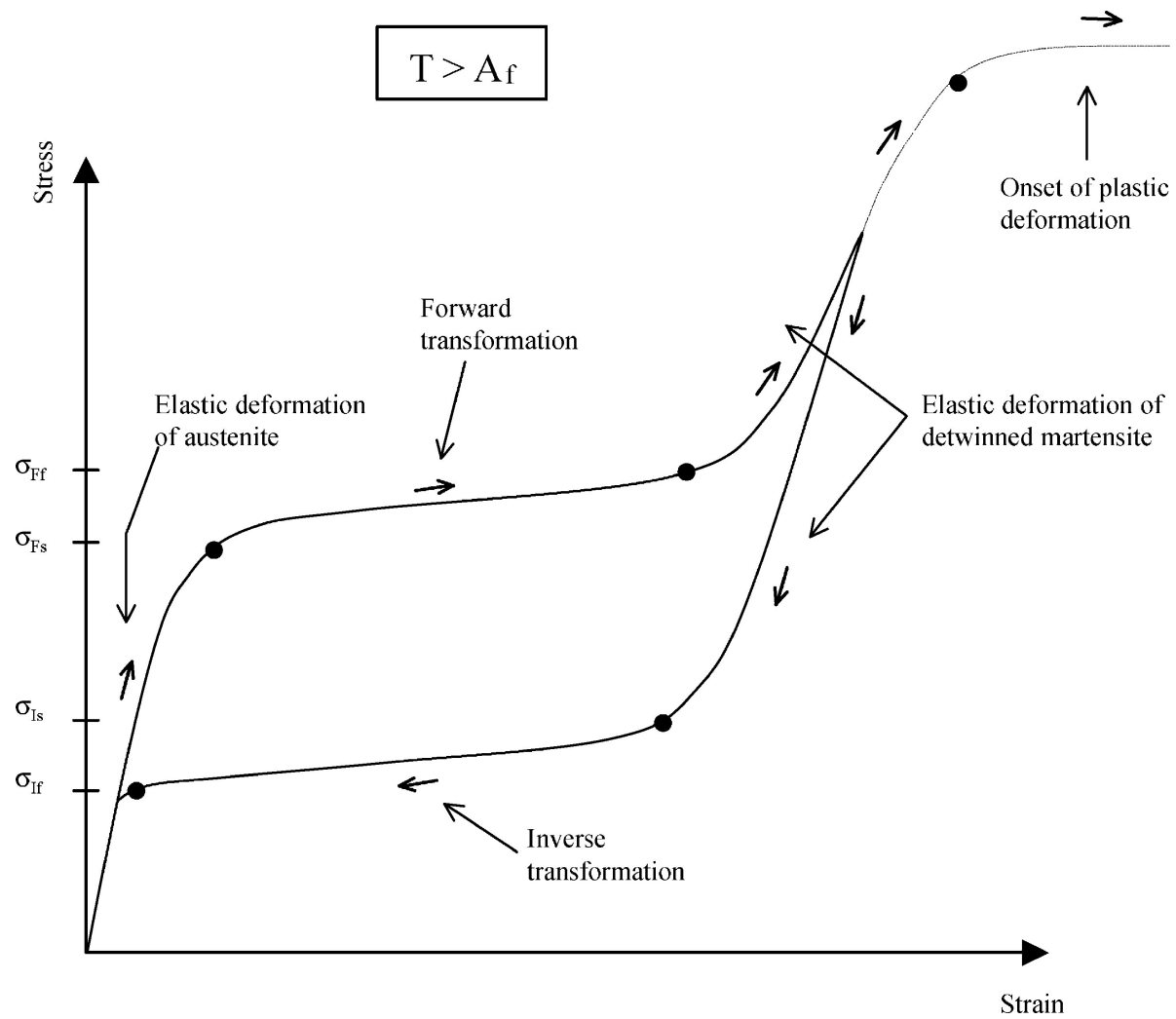

Effetto della deformazione massima

- Con la massima deformazione il damping cresce e quindi l'energia dissipata per ciclo

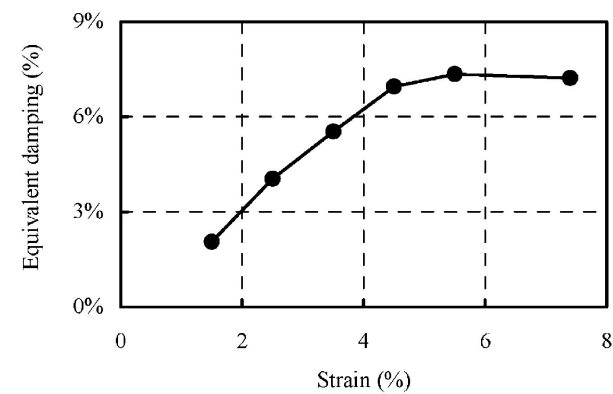
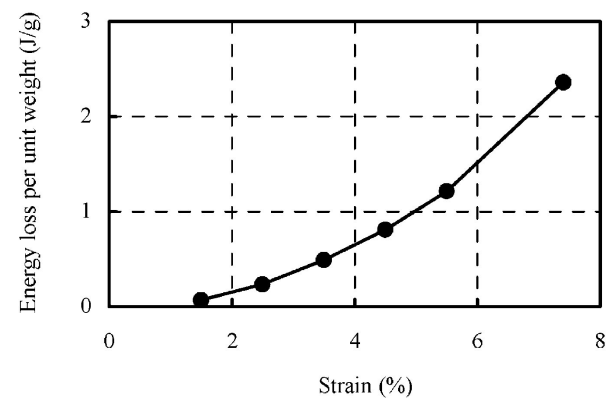
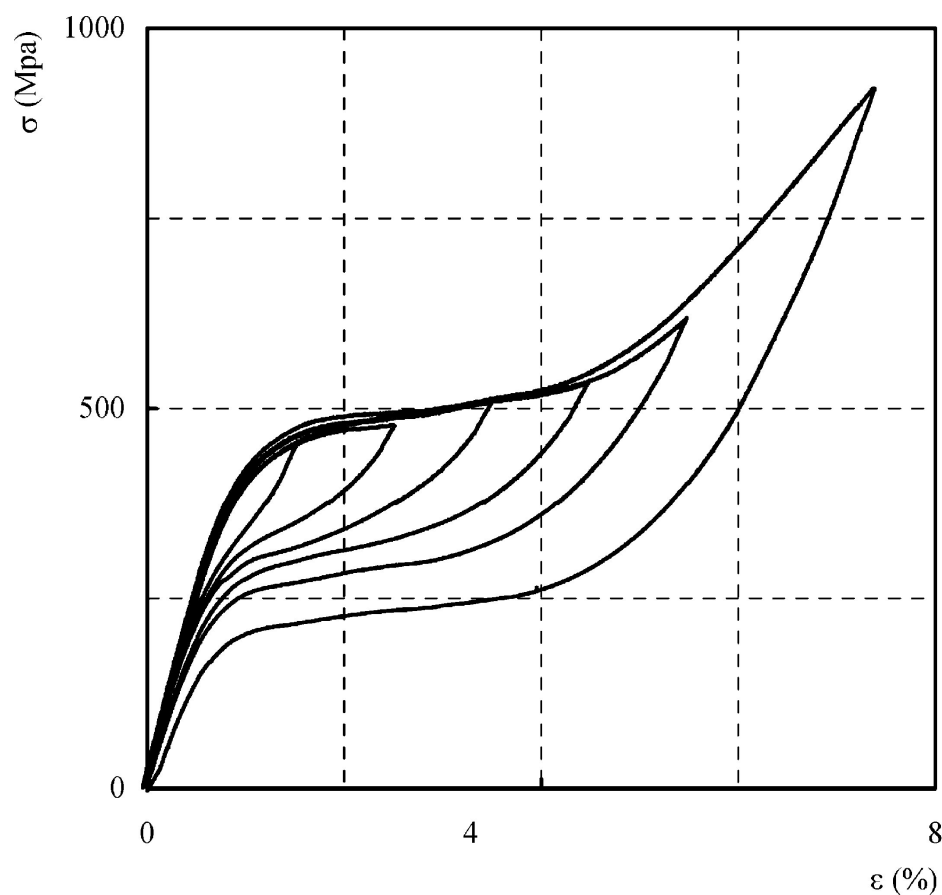

Effetto della configurazione

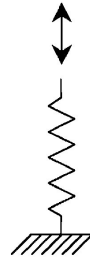
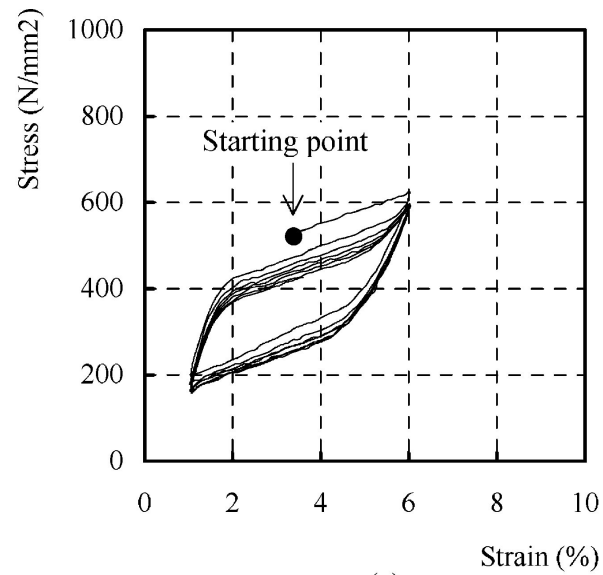

- Si possono avere differenti configurazioni ed effetti sul damping totale

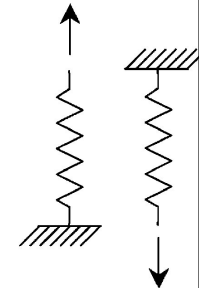
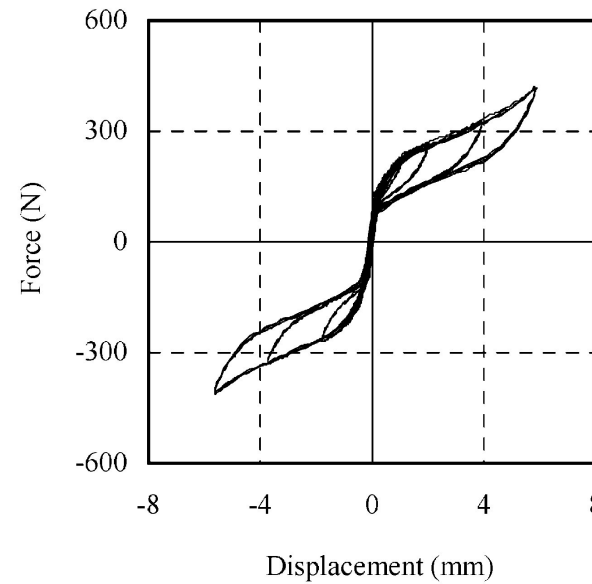
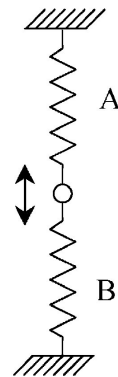
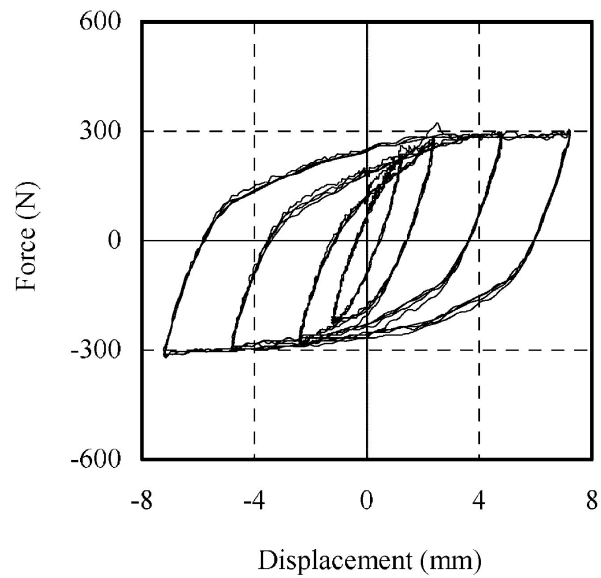

Effetto della temperatura sul damping

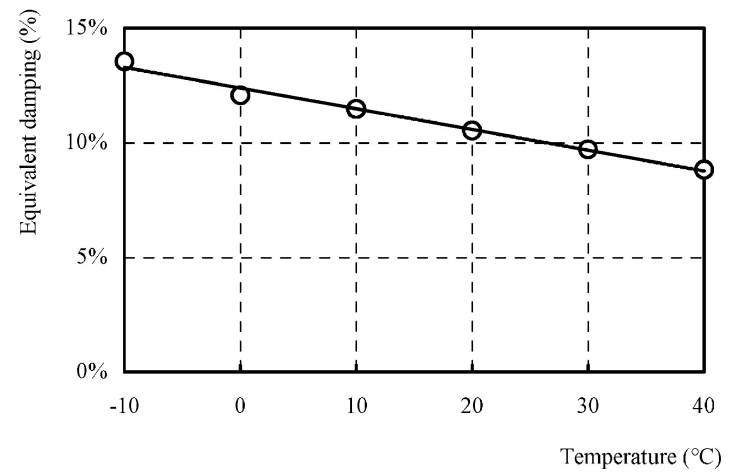
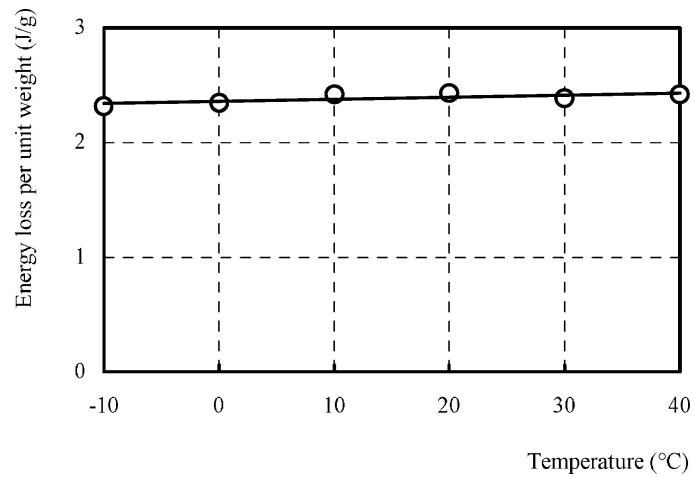
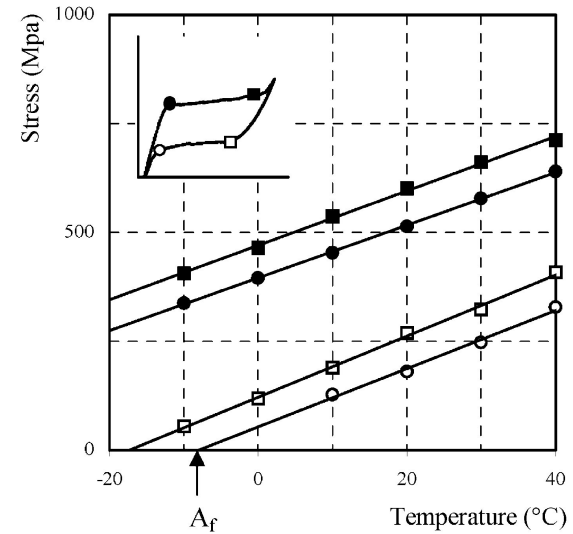
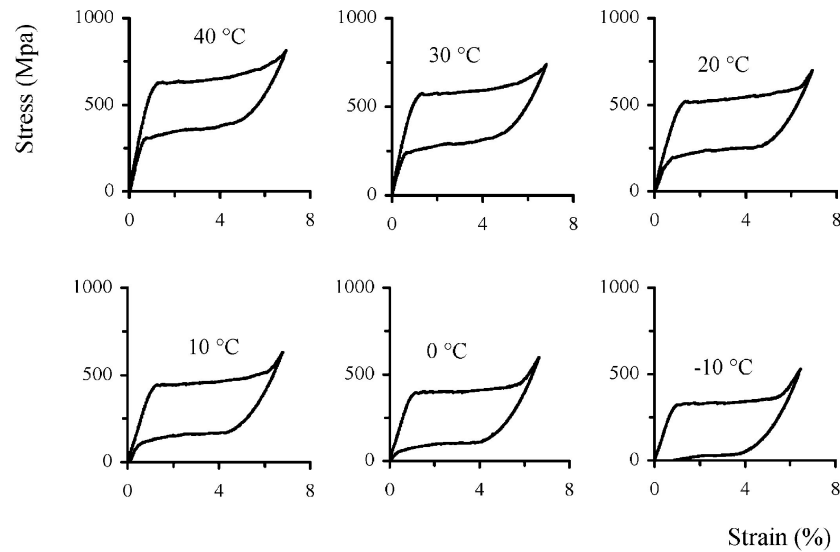

Effetto temperatura- frequenza

- Frequenze più alte permettono un recupero inferiore e diminuisce la quantità di energia dissipata

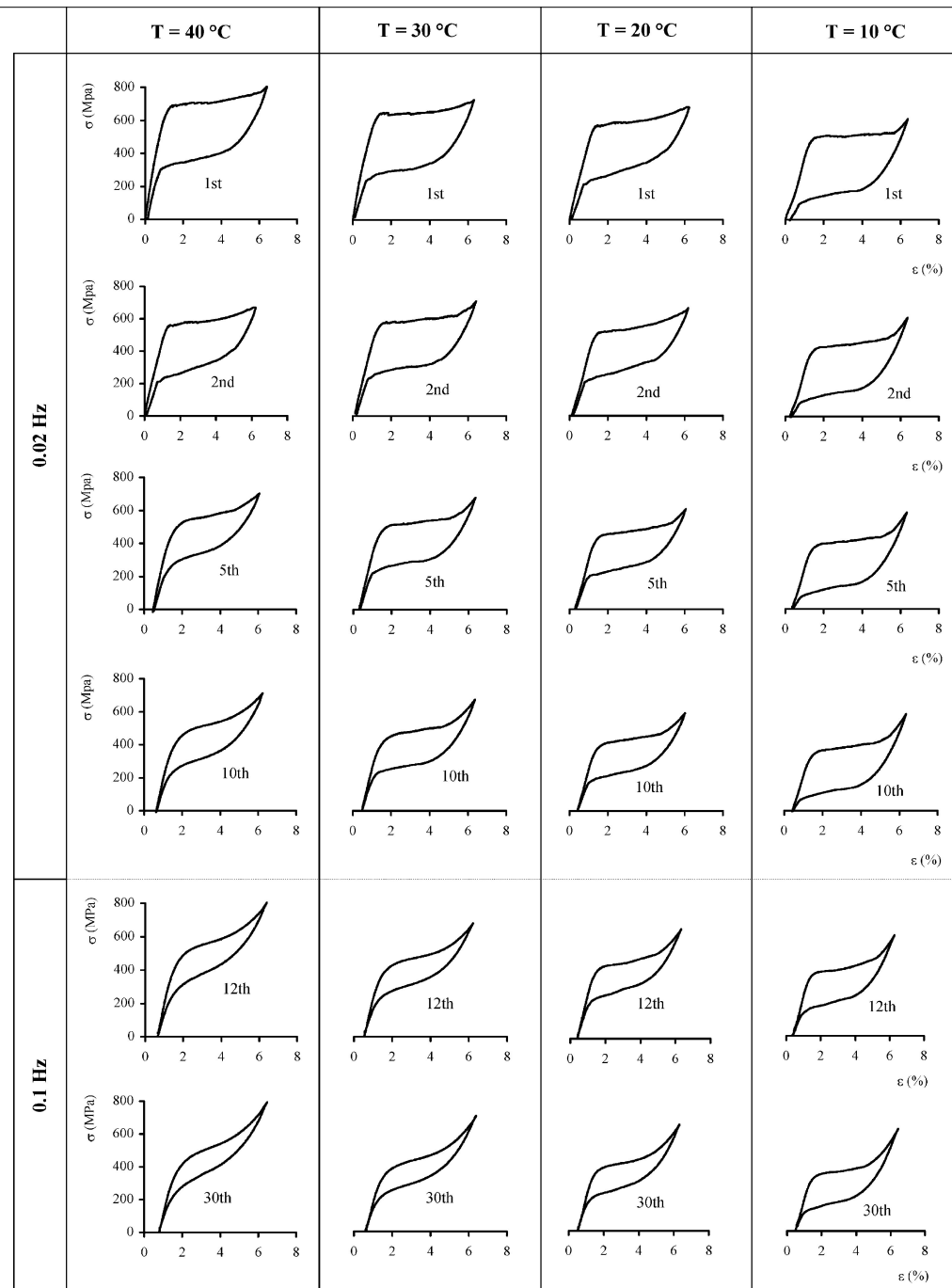

Effetto temperatura-frequenza

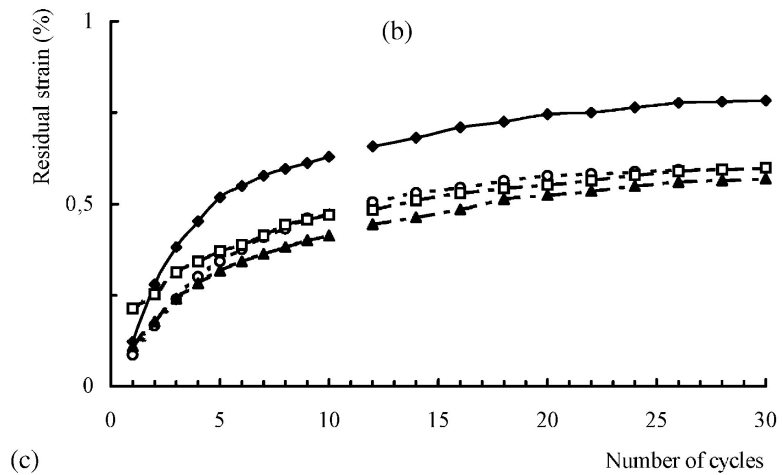
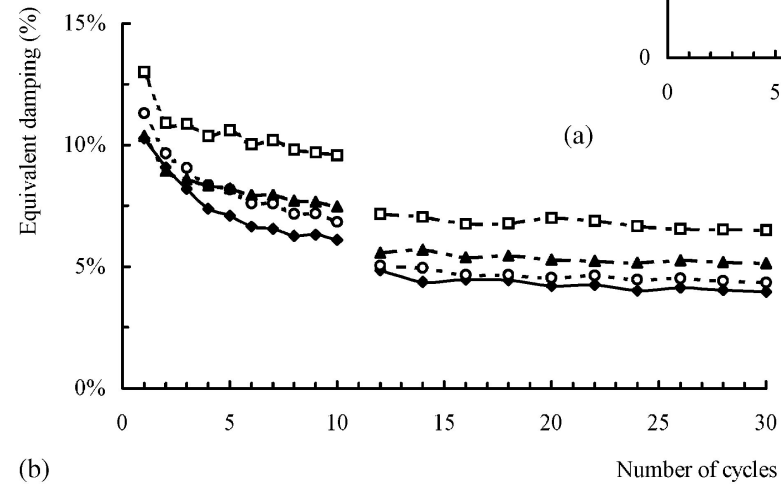
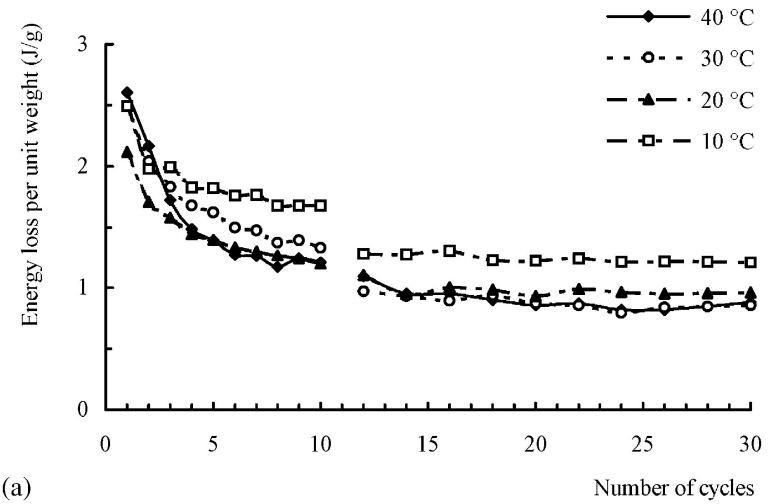

Smorzatori di vibrazione

- Studio smorzatori di Baratta e Corbi. Hanno mostrato come il sistema in SMA mostrava minori spostamenti in risposta a vibrazioni rispetto ad uno perfettamente elastico

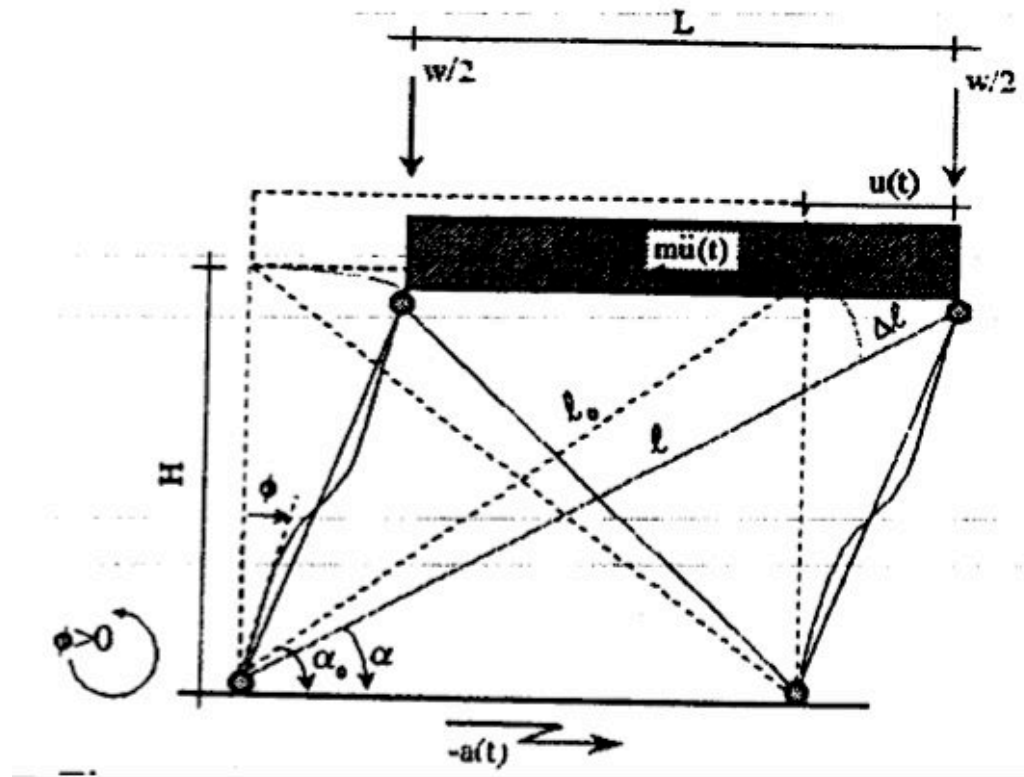

Sistemi smorzatori di De Roches

- De Roches ha studiato diversi sistemi per smorzare le vibrazioni e rinforzare le strutture contro i sismi

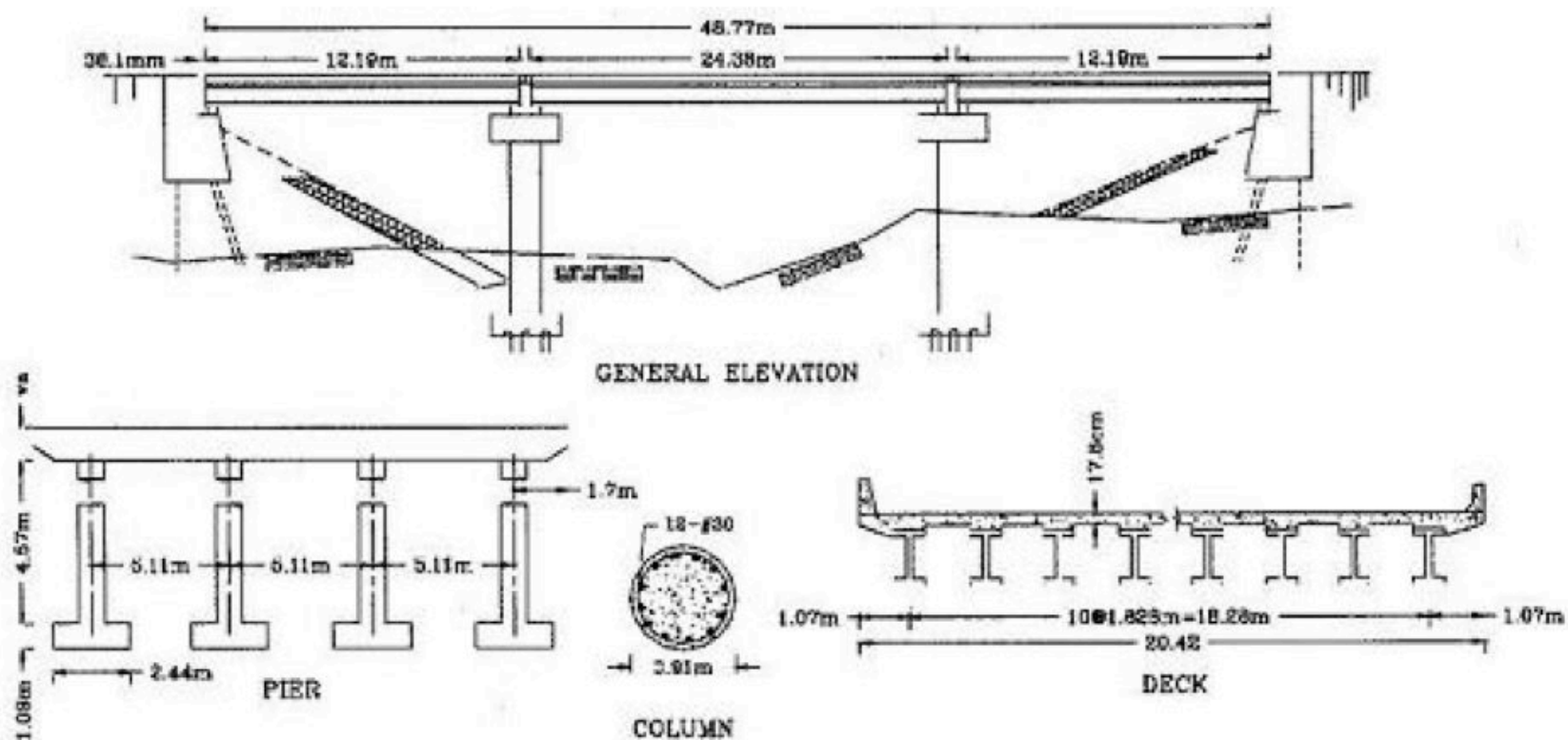

Sstema di rinforzo sismico di De Roches

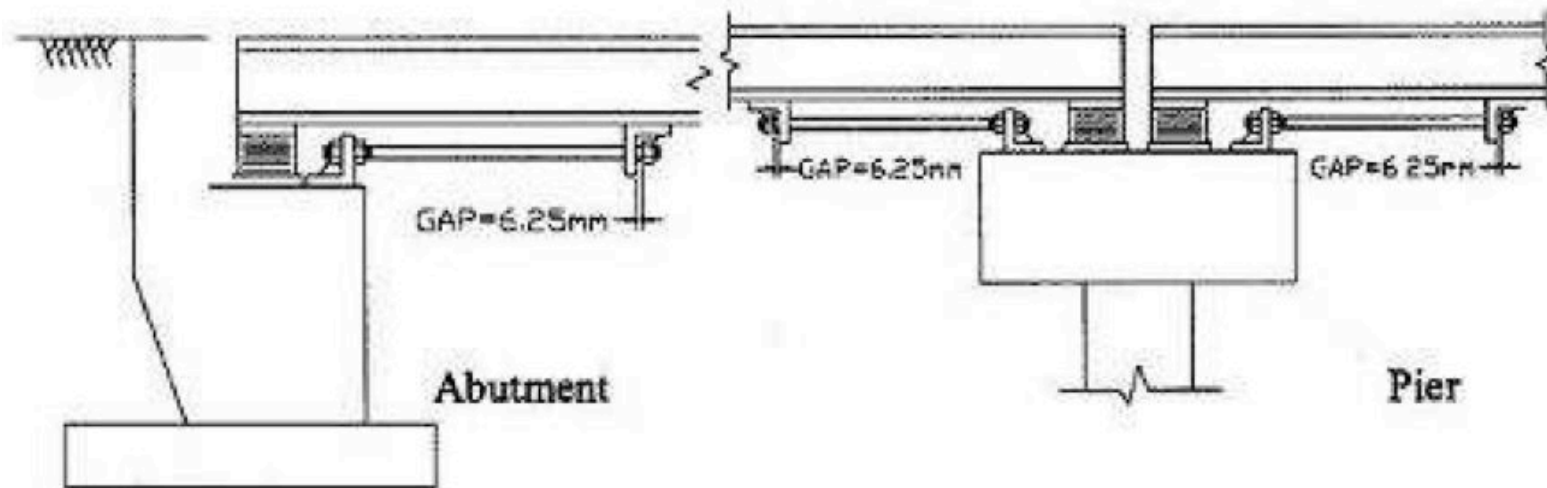

Sistema di rinforzo di Dolce e altri

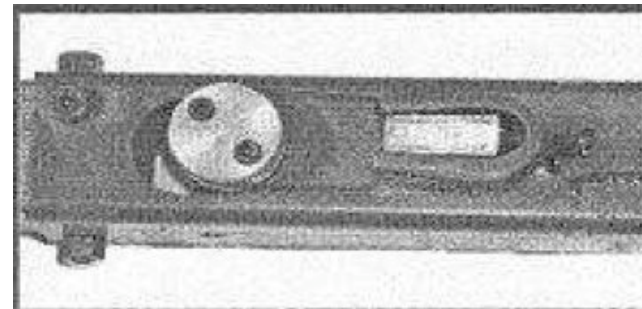
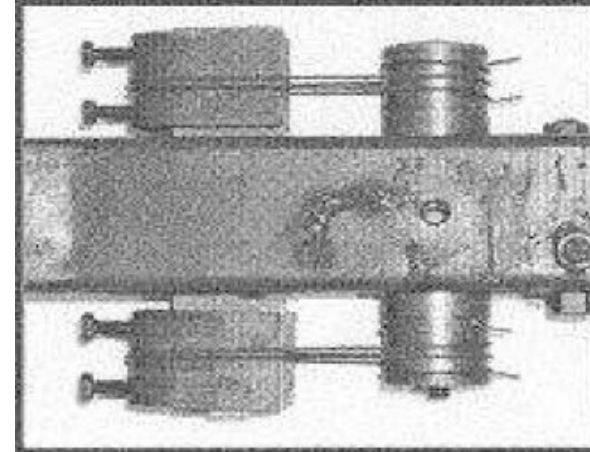
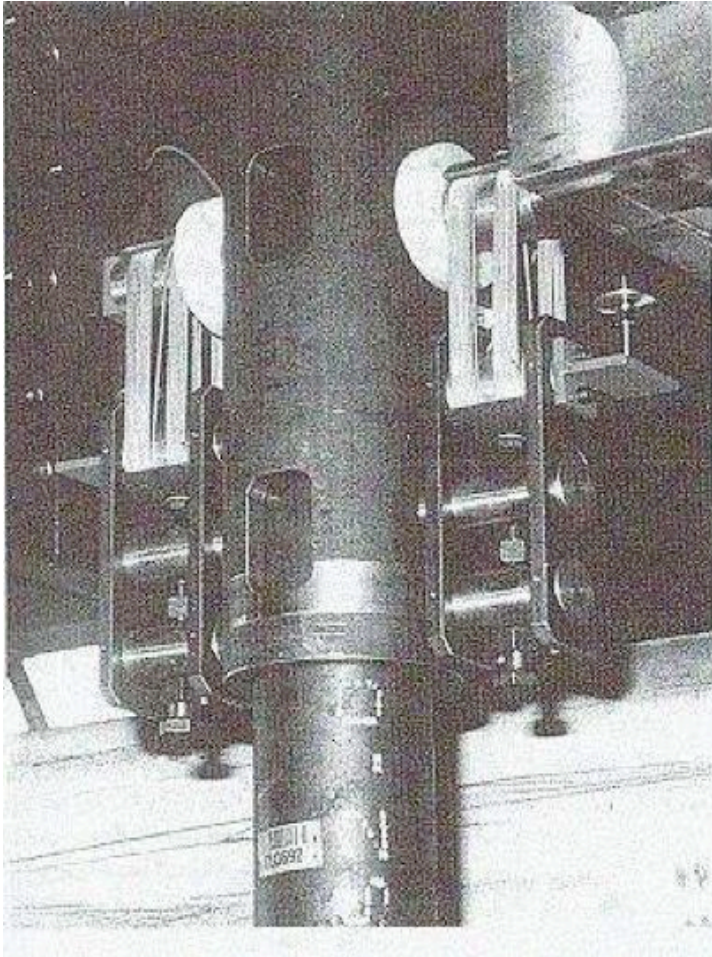

Rinforzo travi con SMA (De Roches)



- In figura una connessione smart di trave e pilone in SMA prima e dopo applicazione di carichi in frequenza elevati. Si veda la deformazione elevata dei tondini in SMA. Dopo riscaldamenti i tondini recuperano la forma originale.

Sistema rinforzo sismico per la basilica di S. Francesco in Assisi



S, Giorgio in Trignano

